

**HIXSON UTILITY DISTRICT**

**WATERLINE**

**STANDARDS**

**AND**

**SPECIFICATIONS**

Revised April 27, 2004  
Revised May 5, 2004 (Drawing TSA-1)  
Revised September 12, 2006 (Drawing WSA-1)  
& pages 8, 9, 45-47 & 49-50  
Revised March 3, 2008 (Drawing FHA-2) & pages 51 & 52  
Revised April 23, 2008 (All Drawings)  
Revised September 9<sup>th</sup>, 2009 (Drawing FHA 2.1)

## INDEX

SECTION	Page
101. Scope	4
103. Design Factors	4
104. Selection of Pressure Class for Water Mains	5
105. Location of Appurtenances	8
106. Installation and Acceptance Testing	8
107. Preparations of Plans Water Distribution Systems	9
108. Water Distribution System Standard Drawings	11
02221 Trenching Backfilling and Compaction	35
02223 Separation of Water Mains and Sewers	41
02305 Boring and Jacking	43
02713 Water Distribution Systems	45
2.07 Fire Hydrants and Blow-off Hydrants	50
3.02 Installing Waterlines	52
3.05 Pressure Tests	53
3.08 Cleaning and Disinfection	55
4.0 Control of Backflow and Cross Connections	56

## STANDARD DRAWINGS

Thrust Blocking Details Tees and Bends and Dead Ends	TBD-1
Thrust Blocking Dimensions	TBD-2
Thrust Blocking Dimensions	TBD-3
Gate Valve and Valve Box	GV-VB-1
Fire Hydrant Assembly	FHA-2.1
Tapping Sleeve Assembly	TSA-1
Reversed Tapping	TSA-2
Water Service Assembly 5/8" & 1" Meters	WSA-1
Water Service Assembly 1 1/2" & 2" Meters	WSA-2
Water Service Assembly Dual Meter	WSA-3
Water Service Assembly 1 1/2" & 2" Turbine Meters	WSA-4
Water Service Assembly 3" Meters	WSA-5
Typical Backflow Preventer Assembly Outside	BP-1
Typical Backflow Preventer Assembly Inside	BP-2
Typical Double Detector Check Valve Assembly Outside	FS-1
Typical Double Detector Check Valve Assembly Inside	FS-2
Backflow Device for Lawn Sprinklers	FS-3
Highway Crossing	HC-1
Installation Detail Blow-off Hydrant No Line Extension	BVA-1
Installation Detail Blow-off Hydrant w/t Line Extension	BVA-2
Joint Deflection Table	JD-1
Push on Joint Assembly Detail	PJA-1
Push on Joint Assembly Detail	PJA-2

## GENERAL

The Design Criteria and Construction Specifications adopted by the Hixson Utility District are from the Tennessee Public Works Construction Standards, published by The University of Tennessee Municipal Technical Advisory Service with modifications for local conditions and District preference.

The section numbering used conforms to the format followed by the Construction Specifications Institute (CSI).

Developers planning improvements to property within the Hixson Utility District service area that will affect water demand from the District or which will involve waterlines that will become District responsibility, will have to follow exactly the Hixson Utility District Waterline Construction Policy, for necessary reviews and approvals prior to starting waterline planning.

Developer needs to contact Utility when construction begins for the purpose of advising on location of water main and inspection during installation.

## DESIGN CRITERIA SECTION

### DESIGN CRITERIA

#### SECTION 100 - WATER DISTRIBUTION SYSTEMS

##### 101 SCOPE

The design criteria for water distribution systems presented hereafter offer basic standards for use in the design process. Much of the information contained herein, as well as additional information may be obtained from the Rules of Tennessee Department of Environment and Conservation – Division of Water Supply, Chapter 1200-5-7, Design Criteria for Public Water.

##### 102 ENGINEER'S REPORT

Not Applicable

##### 103 DESIGN FACTORS

###### 103.1 Source of Water Supply

The source of water supply for the distribution system under design shall be thoroughly investigated to ascertain that it can supply the average and peak daily demands imposed upon it by the proposed system without loss or burden to the existing customers supplied by it.

###### 103.2 Water Consumption

In addition to fire flow requirements, water mains and distribution systems shall be sized for normal consumption demands of 2 gallons per minute per domestic customer or as per Illustration I.

###### 103.3 Fire Flow Requirements

A minimum fire flow of 500 gallons per minute and 30 pounds per square<sup>1</sup> inch residual pressure must be available in all distribution systems containing fire hydrants. The requirements of the Insurance Services

---

<sup>1</sup>On all new waterlines approved beginning April 27,2004

Office and related agencies shall be investigated and complied with if more stringent than the minimum flow set forth above.

103.4 Minimum Size and Cross Country Main Prohibition

All new water main construction must be with 8 inch ductile iron Class 350. The minimum size of water distribution mains shall be that which is required to provide the instantaneous peak demand plus fire flow while maintaining adequate residual pressure. There will be no cross-country main construction unless public right-of-way is unavailable and the cross-country main is in the best Interest of Hixson Utility and is approved by the General Manager and the Board of Commissioners.

103.5 Sizing Water Mains

Water mains shall be sized to provide the instantaneous peak demand plus anticipated fire flow plus any foreseeable future demand while maintaining a minimum of 30 pounds per square inch<sup>2</sup> residual pressure at all points in the system. The pressures losses due to friction must be calculated from the storage or pumping facilities using typical system flows as well as the flows required by the distribution mains being added. From this Information, a hydraulic profile is plotted for submittal to the TDEC-WQC. The plotting shall show the water system hydraulic gradient in relationship to the ground line at all points for the planned extensions and any pertinent points in the existing system. If advantageous, loop analysis may be performed to reduce the losses. If loop analysis is used, a Hardy-Cross or other loop analysis program shall be used. Single path friction loss is readily available from many published tables and monographs or it may be calculated from the Hazen-Williams equation:

$$H_f = 0.002083 L \left[ \frac{100}{C} \right]^{1.85} \times \frac{\text{gpm}^{1.85}}{d^{4.8655}}$$

This equation is based on water at 60 degrees F. and the symbols used are as follows:

$H_f$  = head loss due to friction, feet of water

L = length of pipe including equivalent length for losses through fittings, feet

C = roughness coefficient

gpm = flow of water, gallons per minute

d = inside diameter of circular pipe, inches

The C value varies widely depending on type and age of pipe. For new pipe, the maximum value allowed by the TDEC-WQC is 130.

All calculations and the hydraulic profile shall be submitted to the TDEC-WQC for consideration during their review of the plans and specifications.

104 SELECTION OF PRESSURE CLASS FOR WATER MAINS

---

<sup>2</sup> On all new waterlines approved beginning April 27,2004

#### 104.1 Determination of Maximum and Minimum Pressures Within the System

In the determination of the proper pressure class of pipe materials for use in the system, consideration must be given to the maximum and minimum pressures that will be encountered. The following factors must be considered when determining pressure within a system:

- 1) Highest and lowest elevation of pipelines;
- 2) High and low levels in the water storage reservoirs;
- 3) Booster pumping stations - suction and discharge pressures;
- 4) Fire flow requirements;
- 5) Special control valves, i.e., pressure reducing valves in the system;
- 6) Surge allowance and water hammer; and
- 7) Customer water usage (present and future).

Care must be exercised in evaluating all the parameters involved in the project to insure the customer adequate pressures even under very demanding flow situations.

#### 104.2 Ductile Iron Pipe

Ductile iron pipe is manufactured in seven (7) standard thickness classes, Class 50 through Class 56 and five (5) standard pressure classes, class 100 through class 350. For new water lines less than or equal to 12" diameter pressure class 350 is to be used. Water mains greater than 12" diameter pressure class 250 is to be used

#### 104.3 Polyvinyl Chloride Pipe

NOT ACCEPTED

**ILLUSTRATION 1  
TDEC-WQC DESIGN CRITERIA**

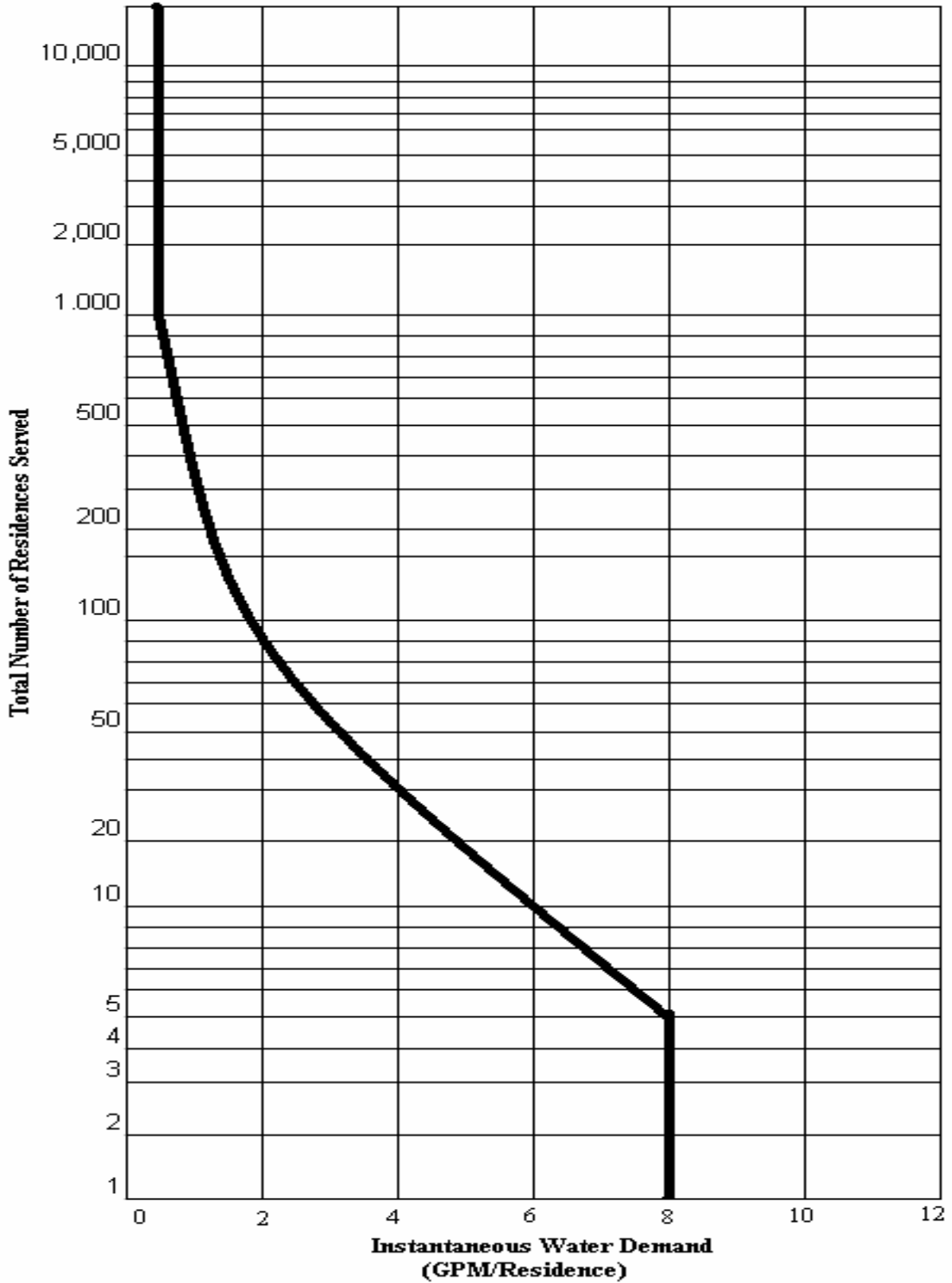

#### 104.4 Other water Pipe Materials

Not Accepted

### 105 LOCATION OF APPURTENANCES

#### 105.1 Control Valves

Control valves (gate valves) shall be placed at all intersections of water mains but at no time greater than 4000 feet apart. Good practice is to limit spacing to 2500 feet.

#### 105.2 Safety Valves

Safety valves (air release, pressure reducing etc.) shall be installed at such locations as deemed necessary for the safe, reliable operations of the distribution systems.

#### 105.3 Fire Hydrants and Blow-Offs

Fire hydrants shall be spaced as recommended by local codes, subdivision regulations, insurance services office, or related for ease of access during fires to both the hydrant and the area served. A fire hydrant shall be located at the end of each extension, unless the local fire department requires a hydrant within 1000 feet of the end of an extension. If a fire department requires a hydrant within 1000 feet of the end of an extension a 4" blow-off hydrant will be used at the end of the extension. Under no conditions will an extension end without a fire hydrant or blow-off hydrant. The details for fire hydrant and blow-off hydrant installation are given in standard drawings FHA-2.1, BVA-1.

#### 105.4 Thrust Blocking

Thrust forces are created in a pipeline at changes in direction, tees, dead ends, or where changes in pipe size occur at reducers. Acceptable restraint methods include concrete thrust blocks, restrained, joints, and tie rods. The details and dimensional data for concrete thrust blocks given in Standard Drawings, TBD 1 and TBD 2 are for 100 pounds per square inch working water pressure and soil bearing loads of approximately 1000 pounds per square foot. For greater pressure or less soil bearing, the quantities required will have to be recalculated, but for pressures less than 100 psi and soil bearing greater than 1000 psi, the thrust blocks shown shall be adequate.

106 INSTALLATION AND ACCEPTANCE TESTING

As a minimum, the specifications shall require acceptance testing to include pressure and leakage testing. Detailed specification for acceptance testing is stipulated in the technical specification AWWA Standard C-600 current edition.

Pressure tests shall be performed at a pressure of 125% of the working pressure at the test point with 200 psi being the minimum test pressure and 250 psi being the maximum test pressure and shall be maintained for two (2) hours. The leakage test shall be conducted concurrently with the pressure test to check for excessive leakage.

All water pipes shall be cleaned and disinfected in accordance with the technical specification AWWA C651 current edition.

107 PREPARATION OF PLANS-WATER DISTRIBUTION SYSTEM

107.1 General

The following requirements for plans is from "Design Criteria For Community Public Water Systems" Published by the Division of Water Management, Tennessee Department of Health and Environment, Nashville, Tennessee, which applies for plan submittals to the State Health Department for the required review and approval.

1.2 Plans - Plans for water works improvement should, where pertinent, provide the following:

1.2.1 General layout, including

- a. title
- b. name of water system, and county in which located
- c. area or institution to be served,
- d. scale, in feet, not less than 1 inch = 200 feet for urban areas, and not less than 1 inch = 400 feet for rural areas,
- e. north direction,
- f. datum used,
- g. boundaries of the municipality or area to be served,
- h. date, address, name, and phone number of the designing engineer,
- i. signed and dated imprint of professional engineer's seal,
- j. legible prints suitable for reproduction, preferably all sheets same size,

- k. location and size of existing water mains, adjacent to proposed construction,
- 1. location and nature of existing water works structures and appurtenances affecting the proposed improvements, noted on one sheet,

1.2.3- Detailed plans for distribution systems, including

- a. a vicinity map showing location of project, if system map is not included,
- b. key map, showing location of detailed drawings, when project is comprehensive,
- c. location of proposed water lines in relation to roads, bridges, and other identifiable objects,
- d. location of valves, fire hydrants, tees, and reducers/ enlargers,
- e. hydraulic profile or data and computations showing hydraulics of proposed additions to the distribution system.

1.3 SPECIFICATIONS

1.3.1. NOT APPLICABLE

1.3.2. The following alternate specifications may be referenced in lieu of submitting new specifications as long as these are applicable to the project:

- a. current, approved standard specifications for the water system on file in our office, (current specifications for the Hixson Utility District).

107.6 Record Drawings

Following the end of construction of the water distribution mains, the tracings shall be revised to reflect any deviations from the plans and provide the precise field location of the water mains, valves, hydrants, services, and other appurtenances. Two copies of the record drawings shall be submitted to the Hixson Utility District.

SECTION 108

WATER DISTRIBUTION SYSTEM

STANDARD DRAWINGS

The following drawings supplement the criteria in Sections 100 through 107. Some are referenced in the criteria while others needed no discussion.

90° BEND							
SIZE	2"	4"	6"	8"	10"	12"	18"
A	16"	16"	26"	33"	40"	50"	70"
B	10"	16"	24"	33"	40"	50"	70"
C	9"	9"	12"	12"	15"	16"	22"
D	6"	3"	12"	16"	20"	25"	24"

45° BEND							
SIZE	2"	4"	6"	8"	10"	12"	18"
A	12"	12"	18"	24"	31"	37"	52"
B	12"	12"	18"	24"	31"	37"	52"
C	8"	8"	10"	12"	14"	16"	14"
D	6"	6"	9"	12"	15"	18"	18"

22-1/2° BEND							
SIZE	2"	4"	6"	8"	10"	12"	18"
A	9"	9"	13"	18"	23"	26"	40"
B	9"	9"	13"	18"	23"	26"	40"
C	8"	8"	10"	12"	14"	16"	15"
D	4"	4"	6"	9"	11"	13"	16"

11-1/2° BEND							
SIZE	2"	4"	6"	8"	10"	12"	18"
A	9"	9"	11"	13"	16"	18"	30"
B	9"	9"	11"	13"	16"	18"	30"
C	8"	8"	10"	12"	14"	16"	15"
D	4"	4"	5"	6"	8"	9"	16"

TEE							
SIZE	2"-6"	8"-12"	3"-10"	12"	12"	12"	18"
A	26"	26"	43"	26"	43"	52"	70"
B	26"	26"	43"	26"	43"	52"	70"
C	12"	12"	12"	12"	12"	12"	30"
D	13"	13"	21"	13"	21"	26"	24"

PLUG							
SIZE	2"	4"	6"	8"	10"	12"	18"
A	26"	26"	26"	34"	43"	52"	70"
B	26"	26"	26"	34"	43"	52"	70"
C	12"	12"	12"	12"	12"	12"	30"
D	11"	11"	11"	15"	22"	32"	32"

THRUST BLOCKING DIMENSIONS TBD2

Table of Dimensions for Concrete Blocking  
(inches)

Pipe Size	Tees, Plugs Crosses					90 Bends				
	H1	H2	V	D	CU FT.	H1	H2	V	D	CU FT.
2 & 2 1/4	18	10	12	18	1.9	18	10	12	18	1.5
3 & 4	24	12	12	18	2.3	24	12	12	18	1.6
6	24	16	18	18	3.5	30	16	16	18	3.2
8	36	18	18	18	5.1	39	18	18	18	4.0
10	48	24	18	24	7.2	54	32	21	18	4.6
12	54	30	24	24	13.4	54	32	24	24	9.6
14	60	21	30	24	17.9	60	40	30	24	13.2
16	60	34	36	24	22.5	69	48	36	24	17.0
18	72	36	40	24	30.0	72	48	42	24	21.0
20	84	38	42	24	36.0	84	48	46	24	27.0

Pipe Size	45 Bends					22 1/2 Bends				
	H1	H2	V	D	CU FT.	H1	H2	V	D	CU FT.
2 & 2 1/4	18	6	12	18	1.5	18	6	12	18	1.5
3 & 4	18	8	12	18	1.6	18	8	12	18	1.6
6	24	10	16	18	3.2	24	10	16	18	3.2
8	24	11	18	18	3.5	24	11	16	18	3.4
10	24	18	21	18	4.6	24	18	21	18	4.6
12	24	18	24	24	6.6	24	18	21	24	6.1
14	30	24	24	24	9.2	27	21	24	24	7.9
16	36	30	27	24	11.8	27	24	27	24	9.1
18	42	30	30	24	15.0	30	30	36	24	13.0
20	48	36	36	24	19.0	42	40	36	24	18.0

Thrust blocks are designed for a working pressure of 350 psig  
and an allowable soil bearing pressure of 2000 psf.

HIXSON UTILITY DISTRICT

THRUST BLOCKING  
DIMENSIONS

DRAWING NO.  
TBD3

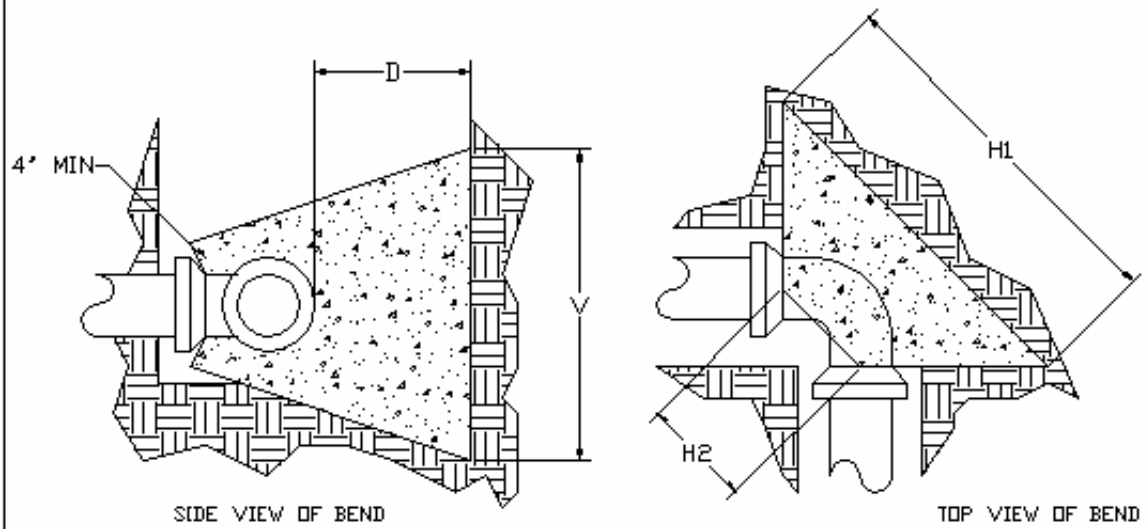
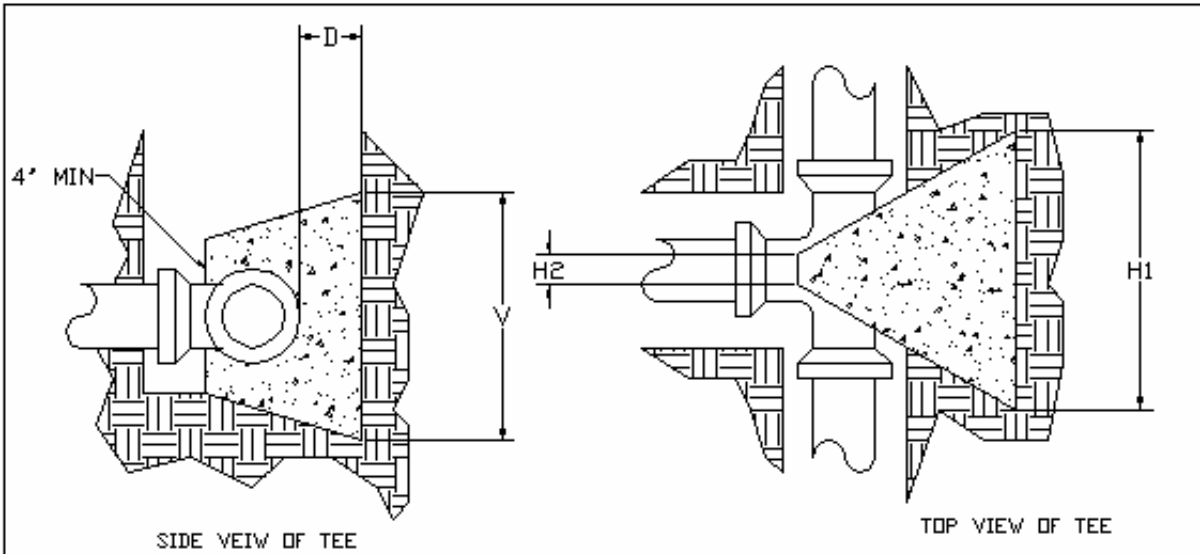

HIXSON UTILITY DISTRICT	THRUST BLOCKING DETAILS FOR TEES AND BENDS	REVISED	DRAWING NO.
			TBD 1

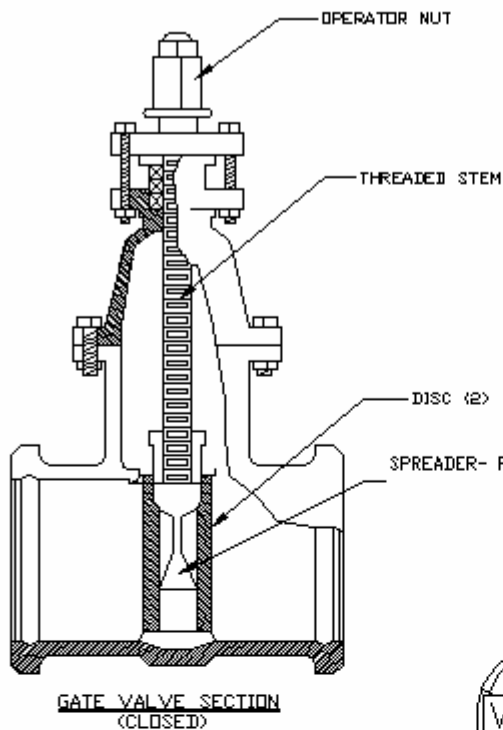

NOTE:  
 AWWA standard C-509 latest edition  
 200 psi working pressure 400 psi  
 test pressure  
 non-rising stem, open left  
 Mueller Series A-2370-20 or  
 U.S. Pipe Metroseal 250  
 or approved equal



**VALVE BOX LTD**  
 Cast Iron, two  
 piece, screw type

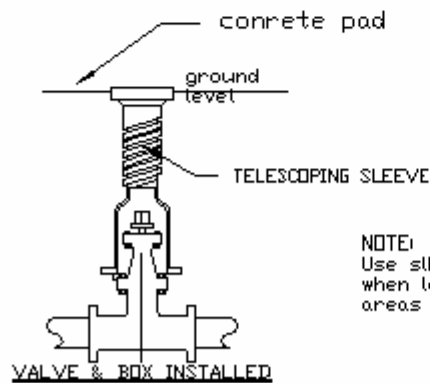

NOTE:  
 Use slip type valve box  
 when located in paved  
 areas and roadways

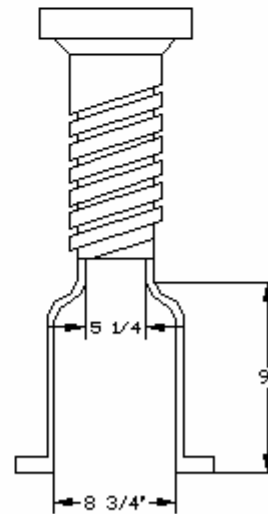

**SCREW TYPE VALVE BOX**  
 As Manufactured by  
 Acheson Foundry or  
 approved equal

HIXSON UTILITY DISTRICT	GATE VALVE & VALVE BOX	REVISED MAR 2008	DRAWING NO.
			GV-VB 1

FIRE HYDRANT AWWA APPROVED  
 CITY OF CHATTANOOGA STANDARD  
 MUELLER SUPER CENTURION 250/HS OR  
 U.S. PIPE METROPOLITAN "G"  
 TRAFFIC MODEL, OPEN  
 LEFT, PAINT YELLOW

Note: ALL FIRE  
 HYDRANTS ARE TO BE  
 INSTALLED ON 8" MAINS  
 OR LARGER

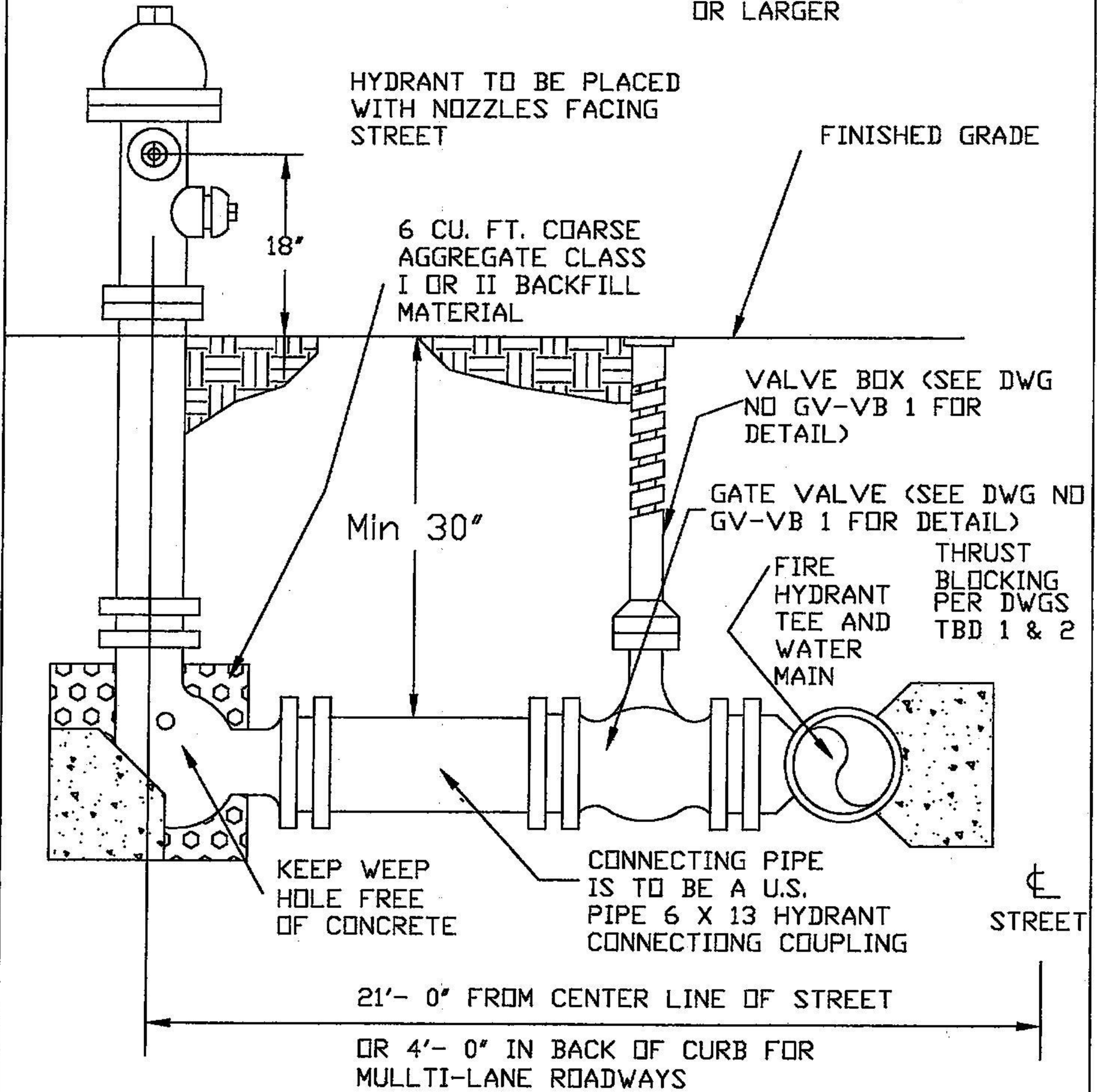

Rev.  
 1  
 SEPT  
 09

HIXSON  
 UTILITY  
 DISTRICT

FIRE HYDRANT ASSEMBLY

DWG  
 FHA  
 2.1

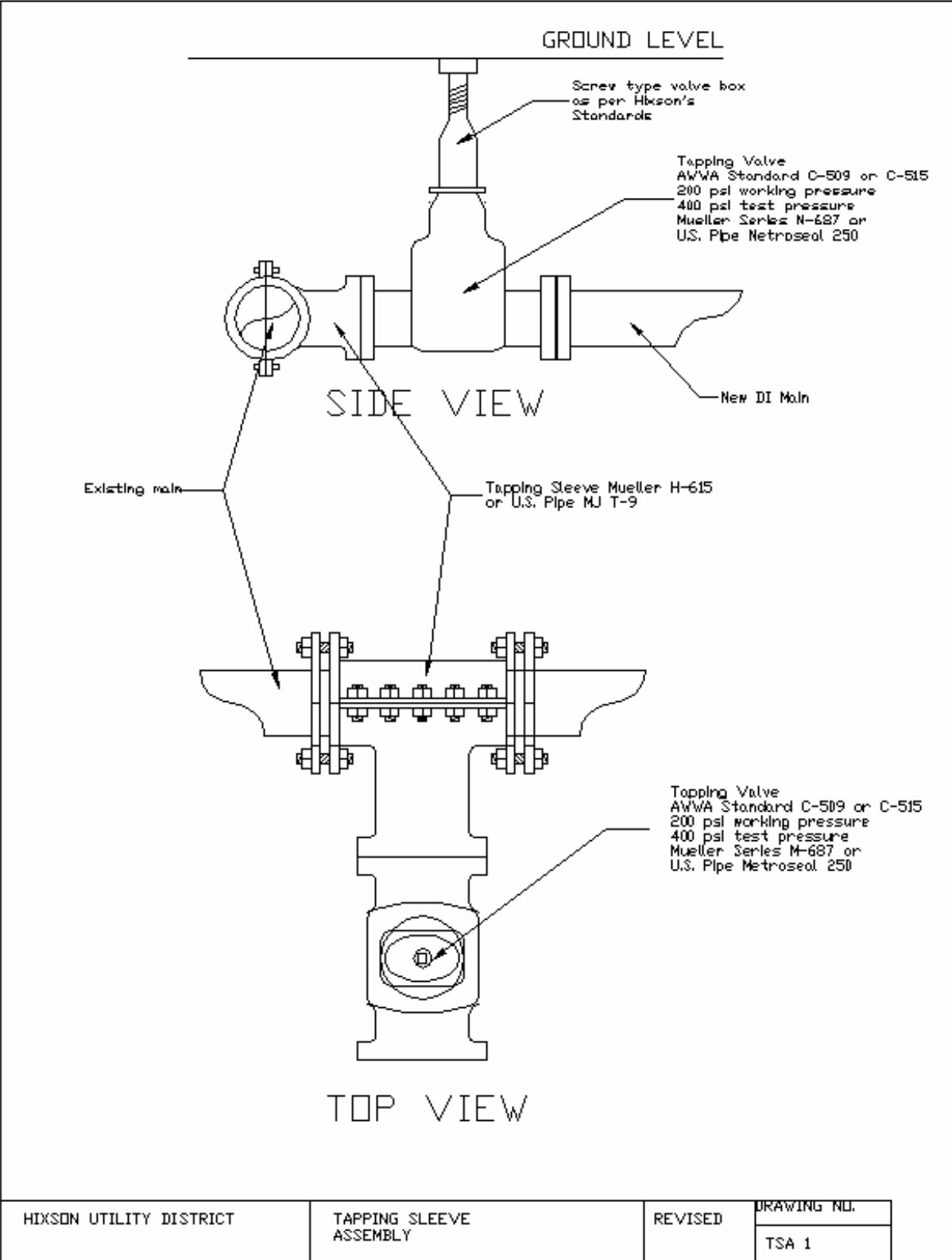

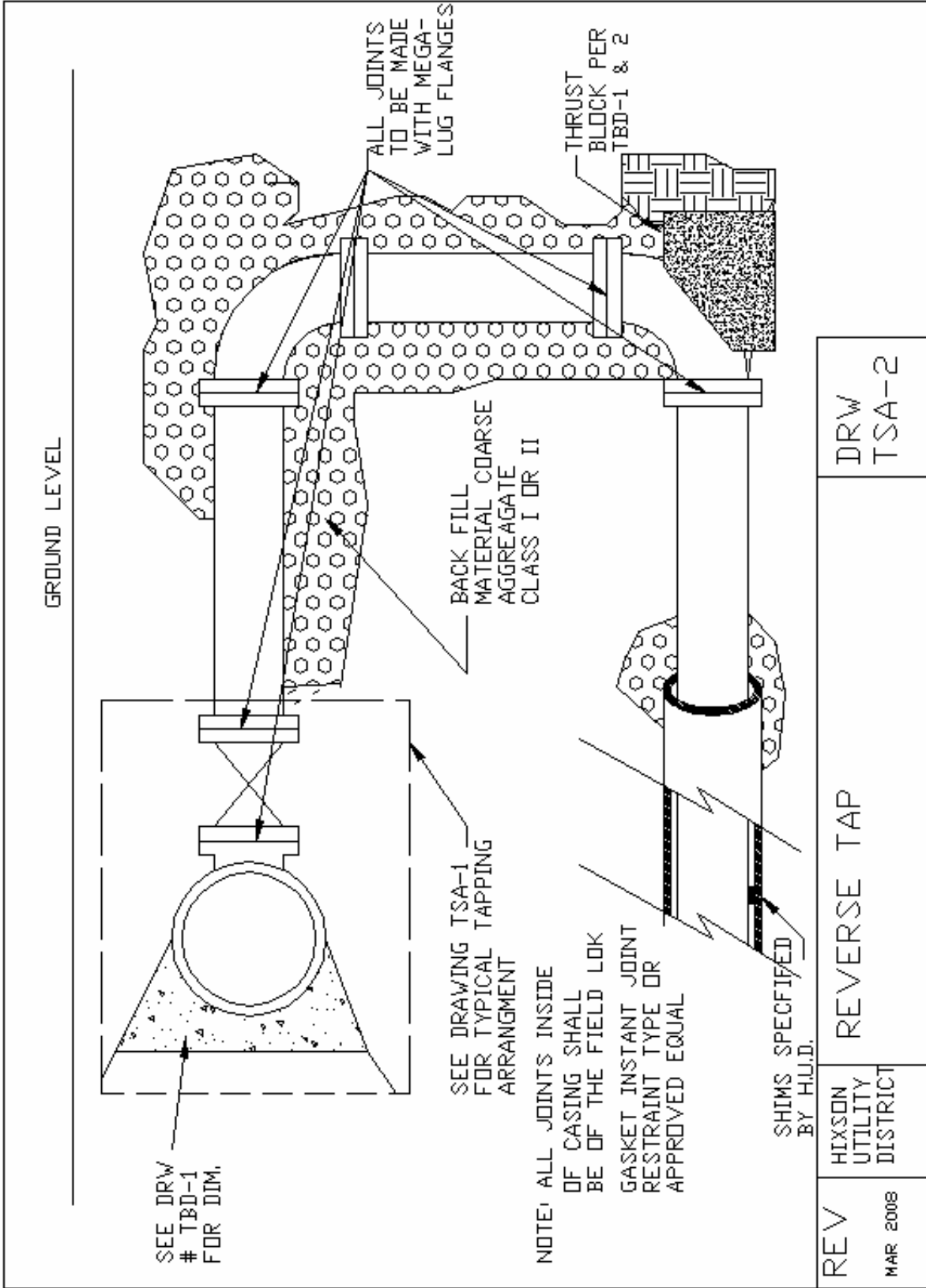

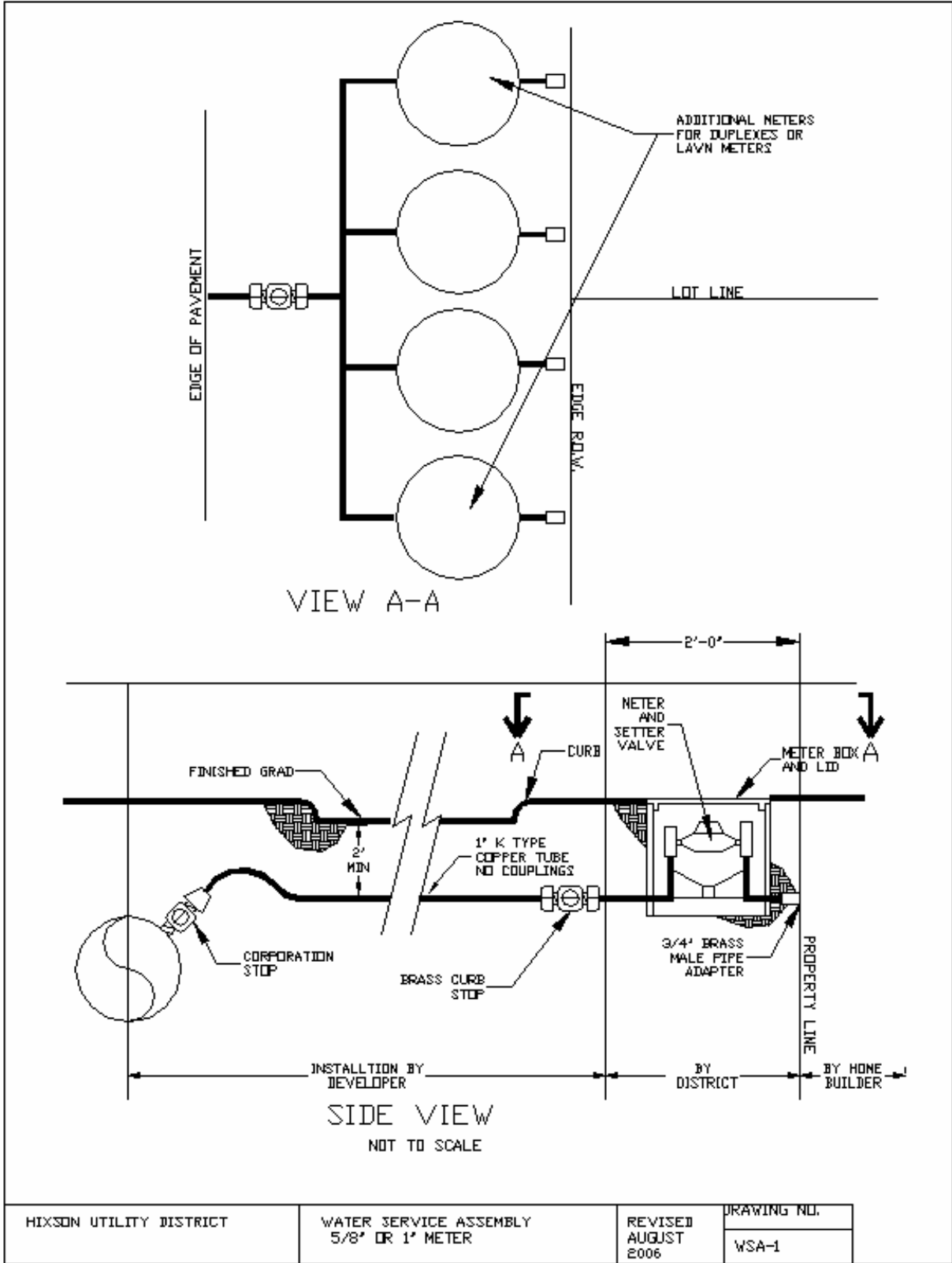

USE SOREY TYPE VALVE BOX  
 24" LENGTH WITH  
 2" RI VALVE

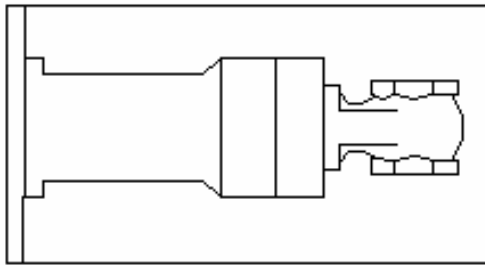

48" X 84" STEEL METER BOX  
 AND LID AS MANUFACTURED  
 BY CHARLES L. COMFEE  
 P.O. BOX 879,  
 CHICKAMAUGA, GA  
 OR APPROVED EQUAL  
 PROVIDE 12" X 18" HOLED  
 DOOR IN COVER OVER METER

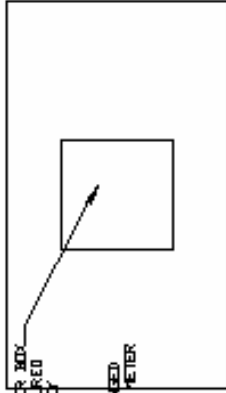

MAIN SIDE

CUSTOMER SIDE

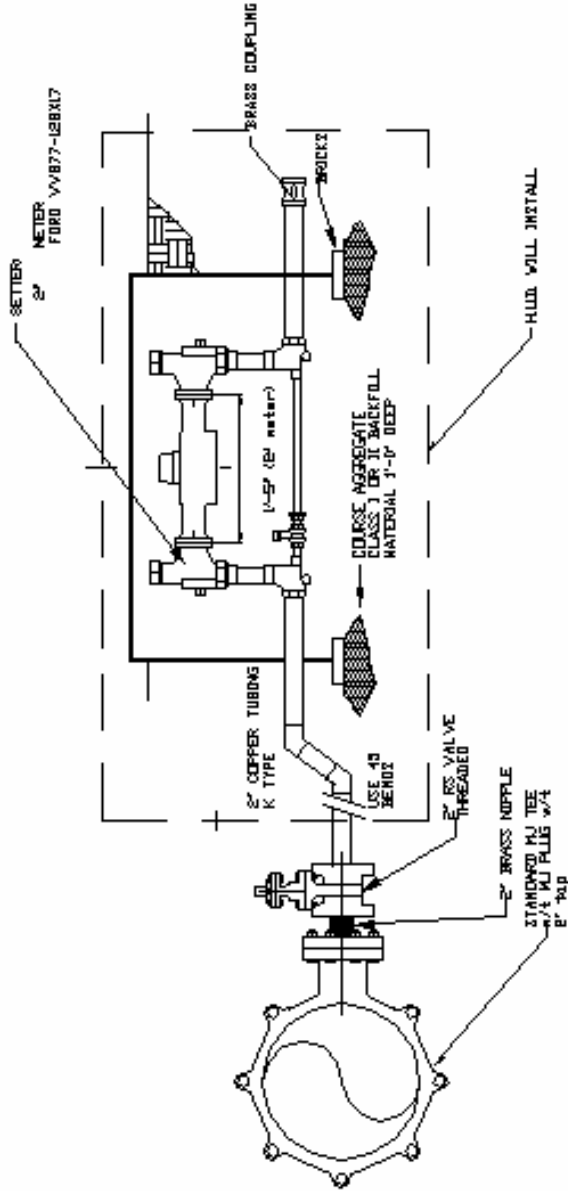

HIXSON UTILITY DISTRICT	NEW CONSTRUCTION INSTALLATION ON OWNERS PIPING 2" METERS	REVISED	DWG NO.
			WSA - 2

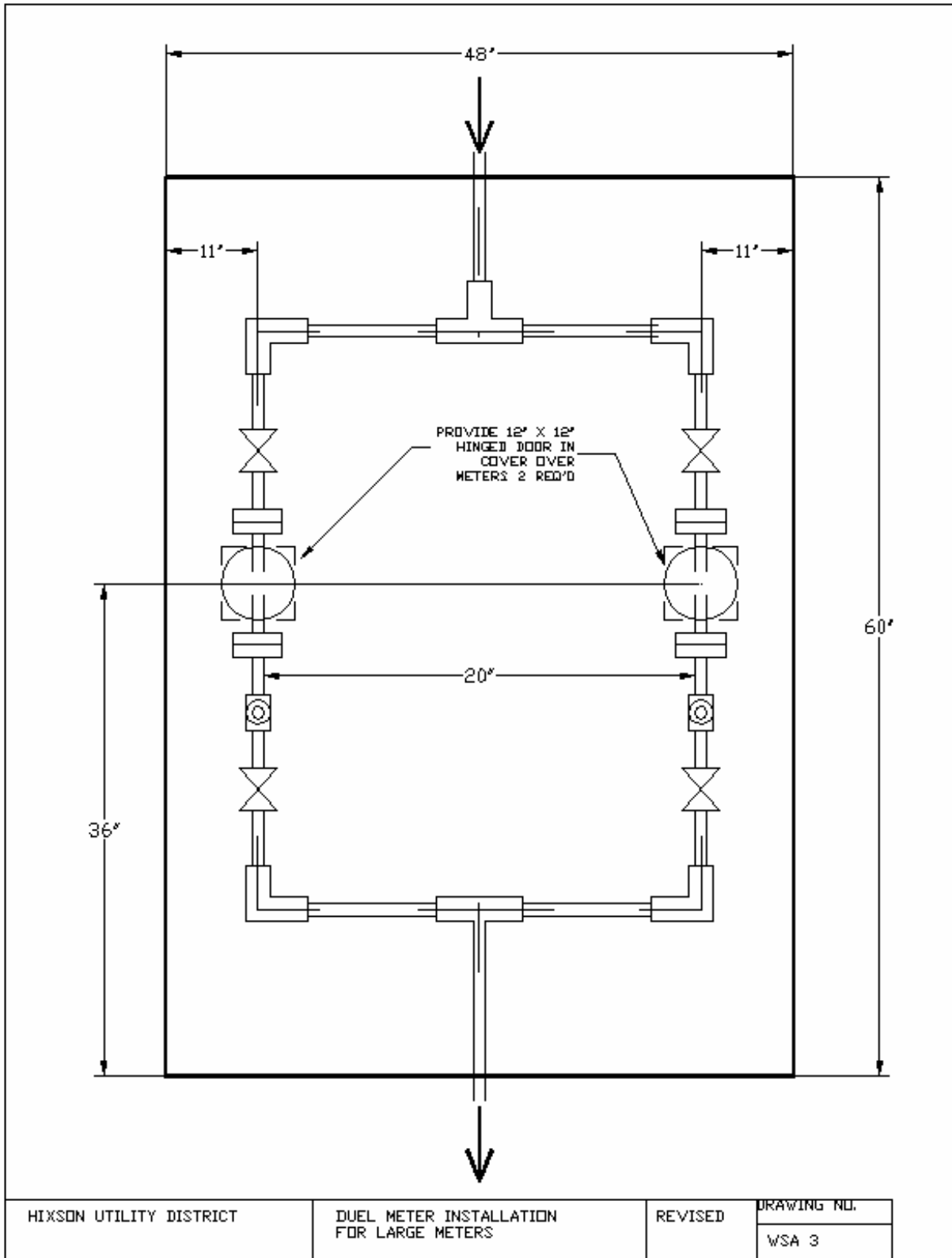

NOTE: ADD BYPASS AROUND METER ONLY IF SERVICE CAN NOT BE SUPPLIED WHEN METER IS TESTED.

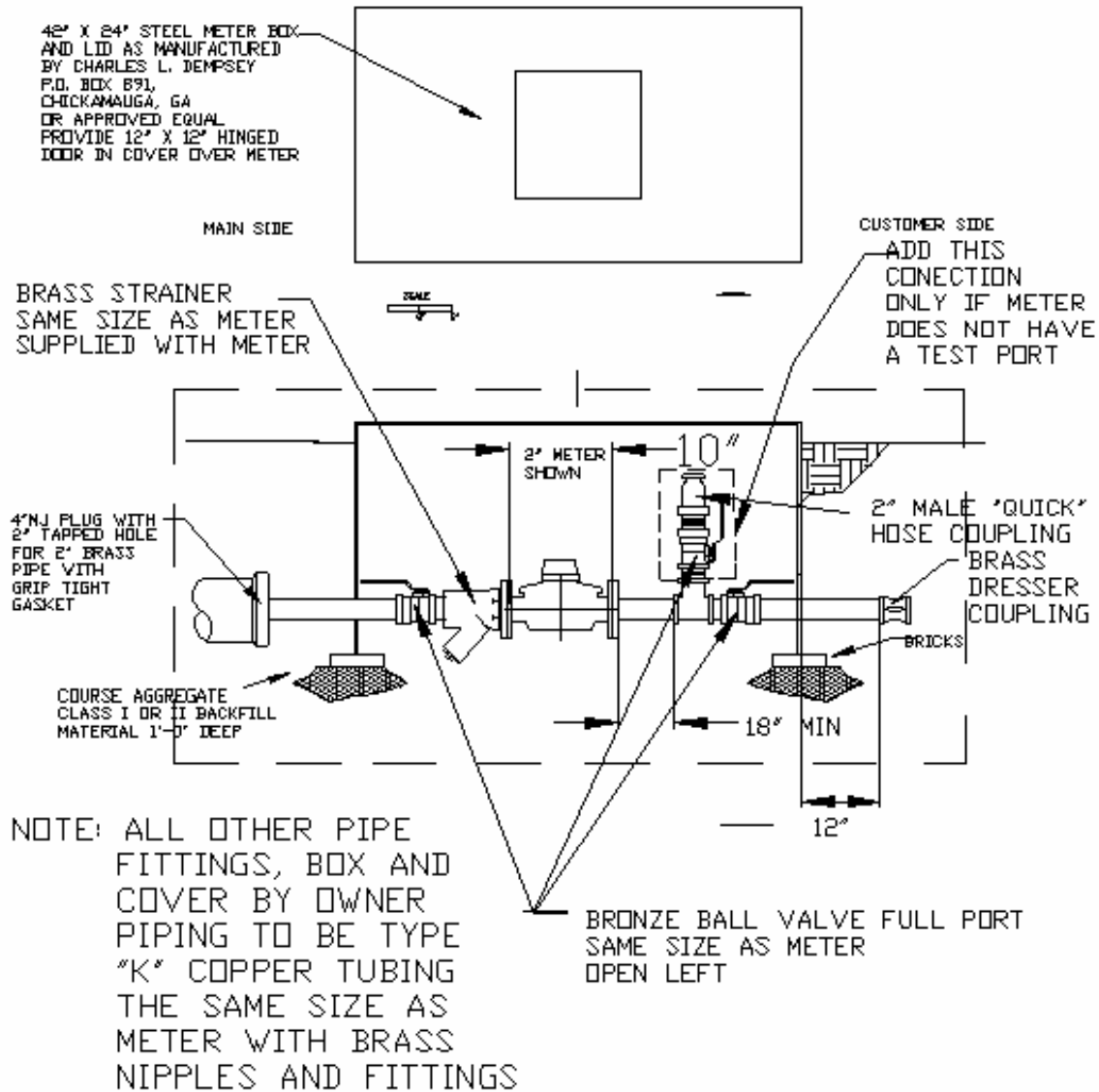

REV.	HIXSON UTILITY DISTRICT	TURBINE METER INSTALLATION ON OWNERS PIPING	DWG NO. WSA - 4
------	-------------------------------	---	--------------------

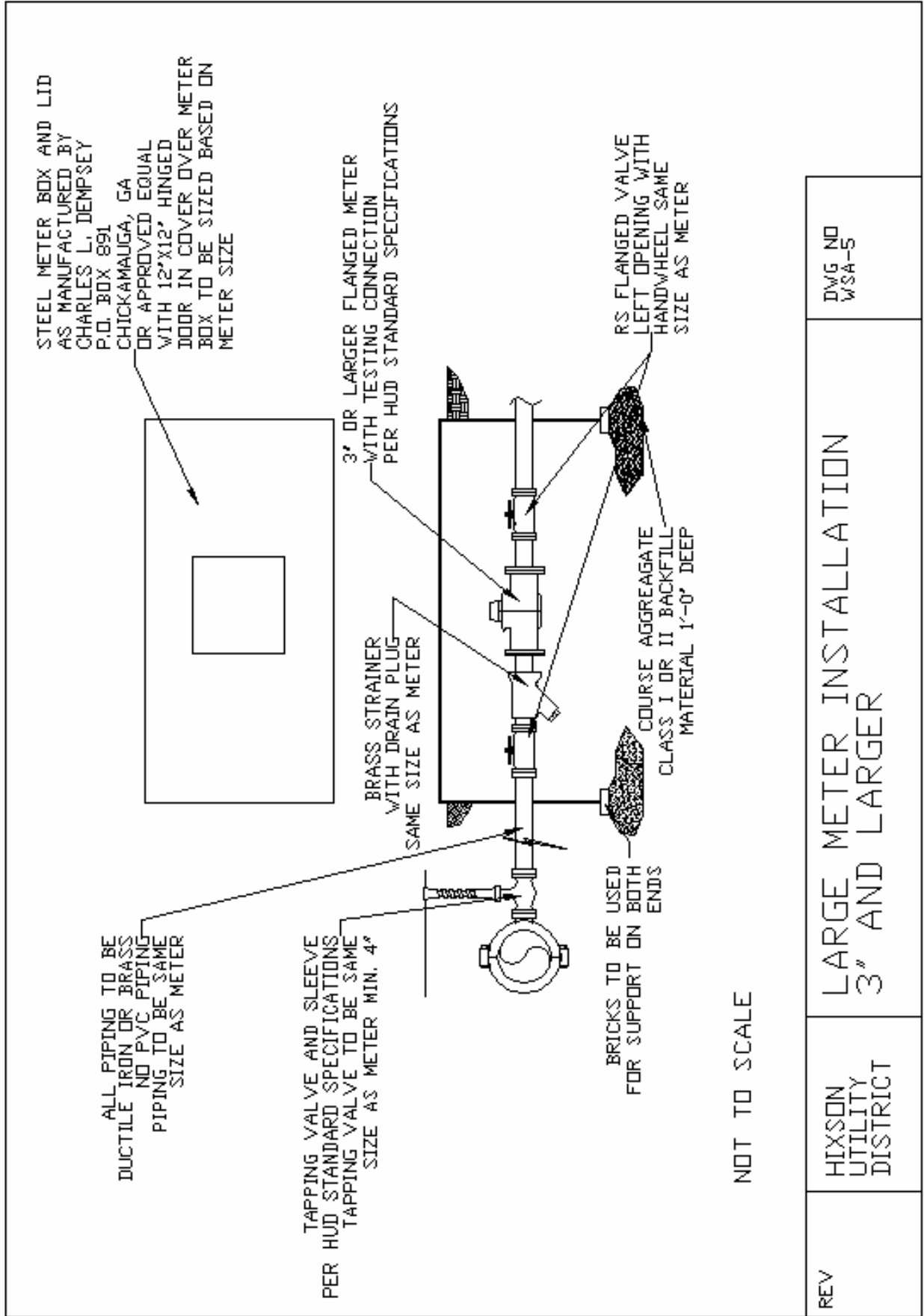

REV	HIXSON UTILITY DISTRICT	LARGE METER INSTALLATION 3" AND LARGER	DWG NO WSA-5
-----	-------------------------------	---	-----------------

- NOTES:
1. PRESSURE REGULATOR OPTIONAL
  2. BACKFLOW PREVENT MUST BE FROM APPROVED LIST OF TDEC.
  3. VALVE OPEN LEFT
  4. 2" AND SMALLER VALVE ARE TO BE FULL PORT BRONZE BALL VALVES.
  5. VALVES LARGER THAN 2" ARE TO BE FULL PORT BRONZE BALL VALVES OR FULL PORT RS TYPE WITH NSF 60 APPROVED EPOXY COATING.

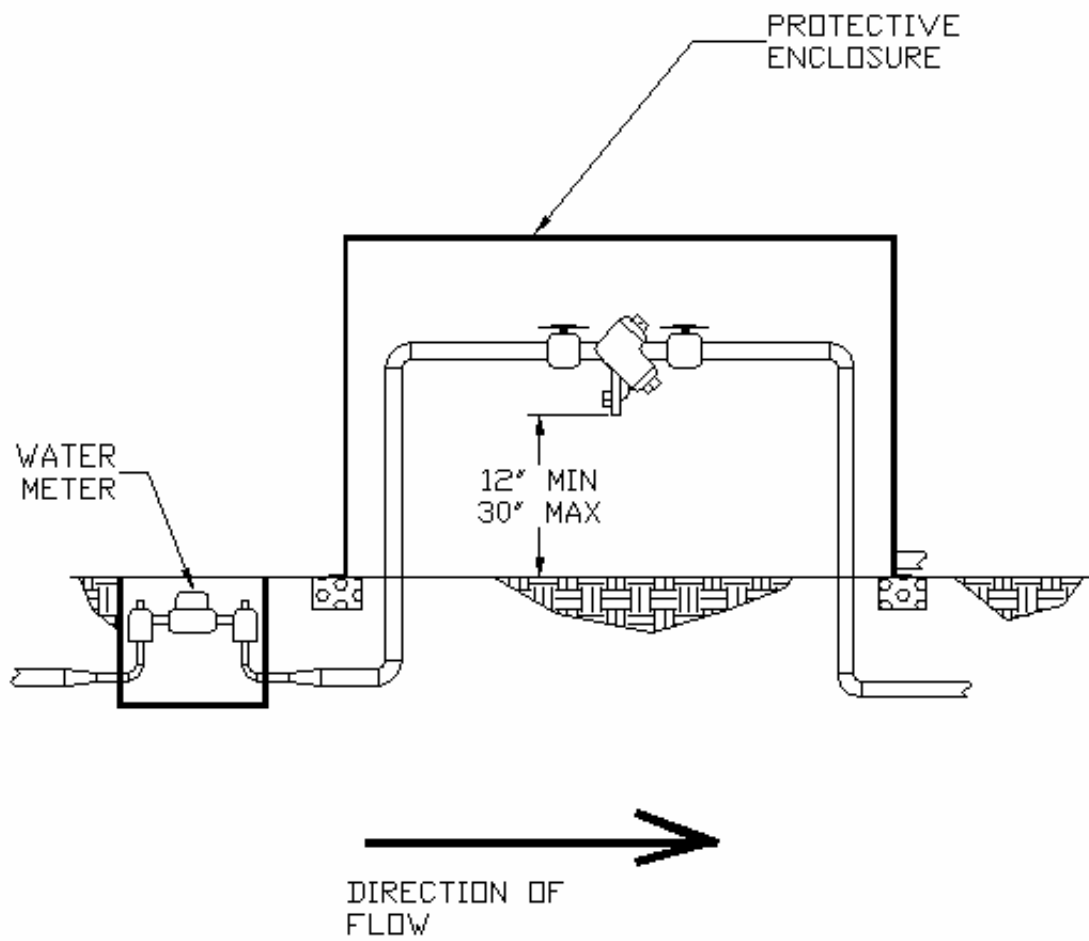

HIXSON UTILITY DISTRICT	TYPICAL BACKFLOW PREVENTER ASSEMBLY OUTSIDE BUILDING	REVISED	DRAWING NO.
		MAR 2008	BP 1

NOTE: A MINIMUM OF  
12" MUST BE  
MAINTAINED BETWEEN  
THE DEVICE AND ALL  
WALLS AND FLOORS.

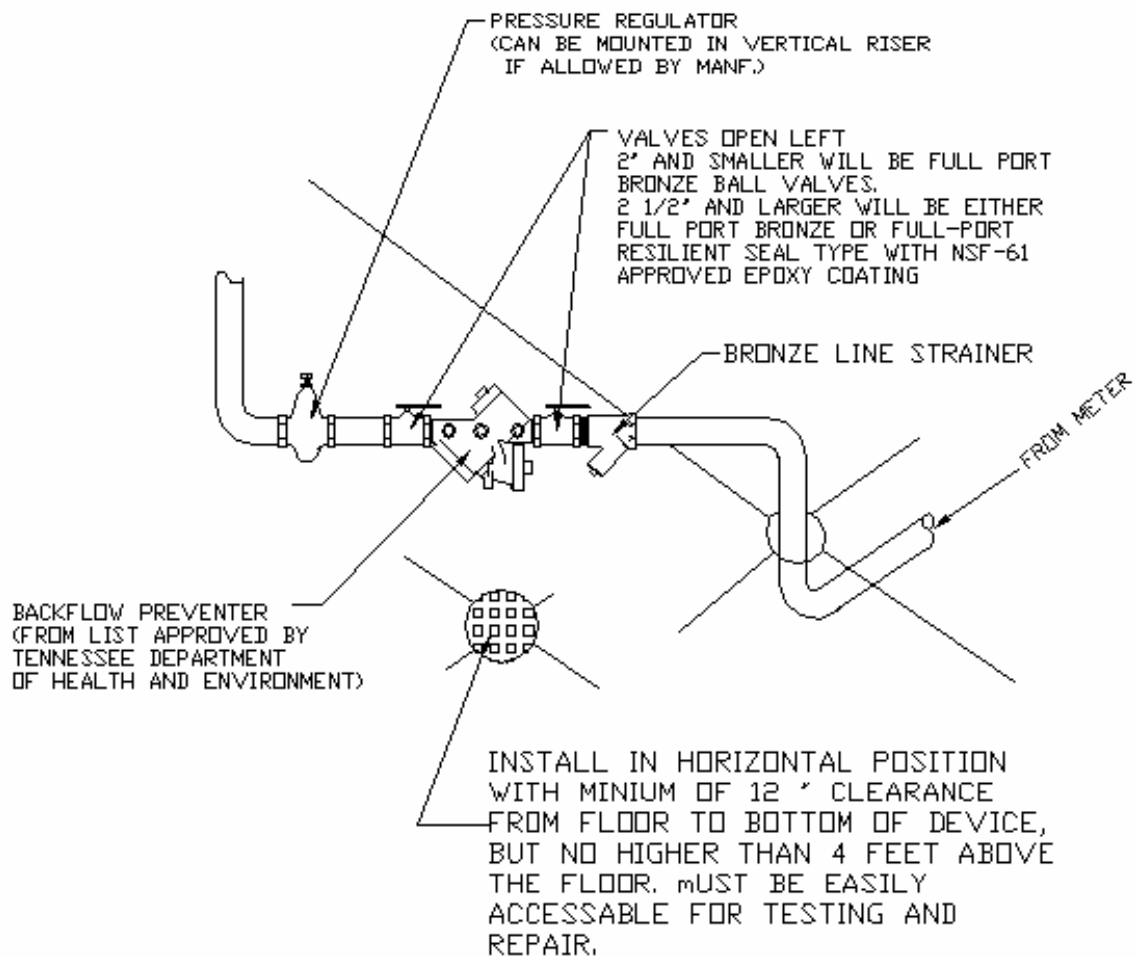

HIXSON  
UTILITY  
DISTRICT

TYPICAL BACKFLOW PREVENTER  
ASSEMBLY  
INSIDE BUILDING

DWG.  
BP-2

H.U.D. APPROVAL REQ'D PRIOR TO  
 INSTALLATION.  
 INSTALLATION PRIOR TO APPROVAL  
 WILL NOT BE ACCEPTED.

NOTE: ALL ITEMS ON THIS  
 SIDE TO MEET H.U.D.  
 SPECIFICATIONS

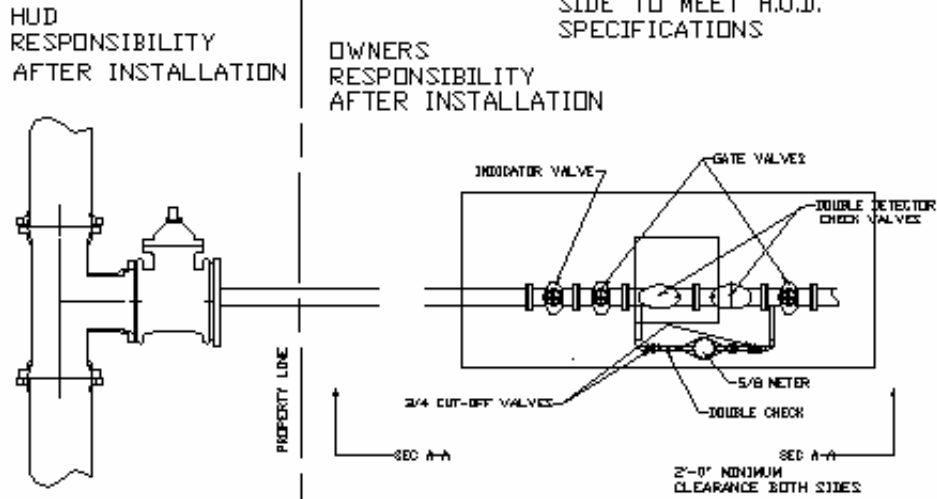

CUSTOMER TO SUPPLY  
 TAP SLEEVE AND VALVE  
 AS SPECIFIED BY H.U.D.  
 SPECS AND PAY TAP  
 FEE.  
 H.U.D. WILL MAKE  
 TAP AND INSTALL SLEEVE  
 AND VALVE.

42" X 24" MIN STEEL METER BOX  
 AND LID AS MANUFACTURED BY  
 CHARLES L. DEMPSEY  
 CHICKKAMUGA GA  
 PROVIDE 12" X12" HINGED  
 INSPECTION COVER.

LOCATION NOTE:  
 DEVICE IS REQ'D  
 TO HAVE A MINIMUM  
 CLEARANCE OF 12"  
 FROM ALL WALLS  
 AND FLOORS

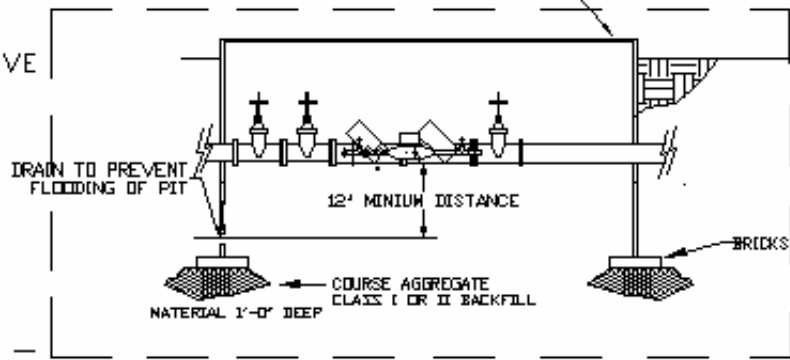

SECTION A-A

REV	HIXSON UTILITY DISTRICT	TYPICAL DOUBLE DETECTOR CHECK VALVE ASSEMBLY (PIT INSTALLATION)	DWG FS-1
-----	-------------------------------	---	-------------

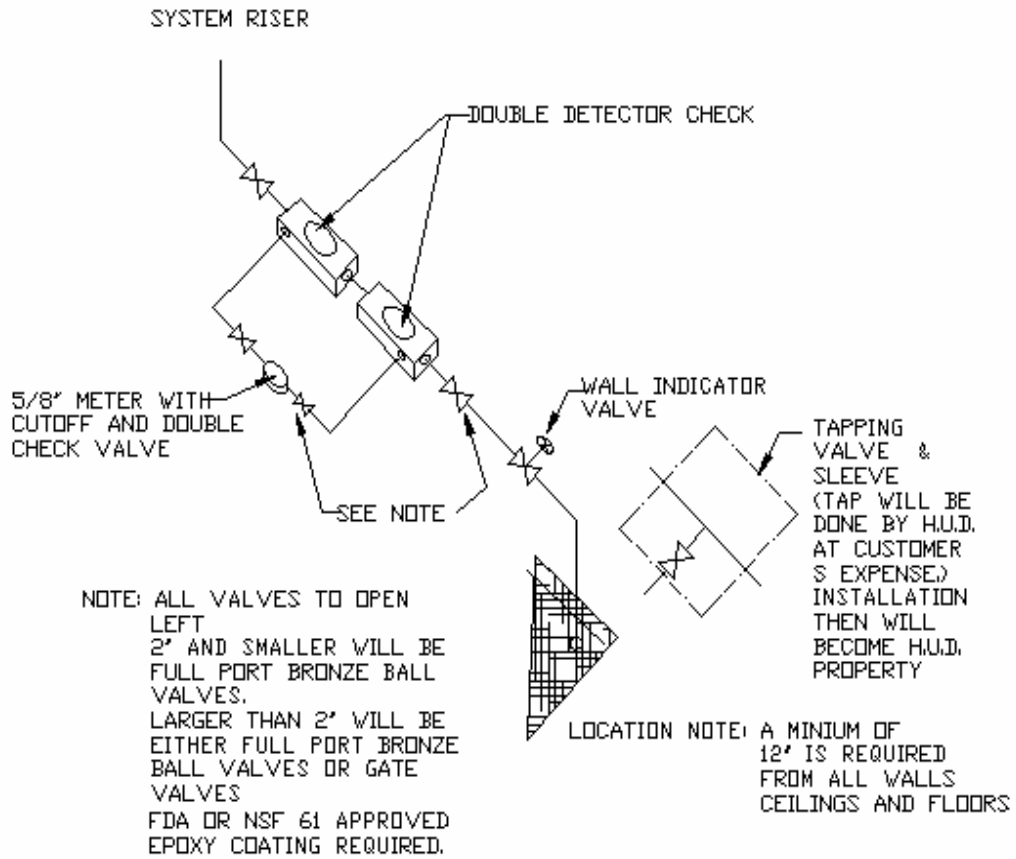

REV	HIXSON UTILITY DISTRICT	SPRINKLER SYSTEM TYPICAL DOUBLE DETECTOR CHECK VALVE INSTALLATION (INSIDE BUILDING)	DRW FS-2
-----	-------------------------------	--	-------------

- NOTES:  
 1 2" AND SMALLER VALVES  
 ARE TO BE FULL PORT  
 BRONZE BALL VALVES  
 2 VALVES LARGER THAN 2"  
 ARE TO BE EITHER FULL  
 PORT BRONZE BALL  
 VALVES OR FULL PORT RS  
 TYPE WITH NSF 60  
 APPROVED EPOXY  
 COATING

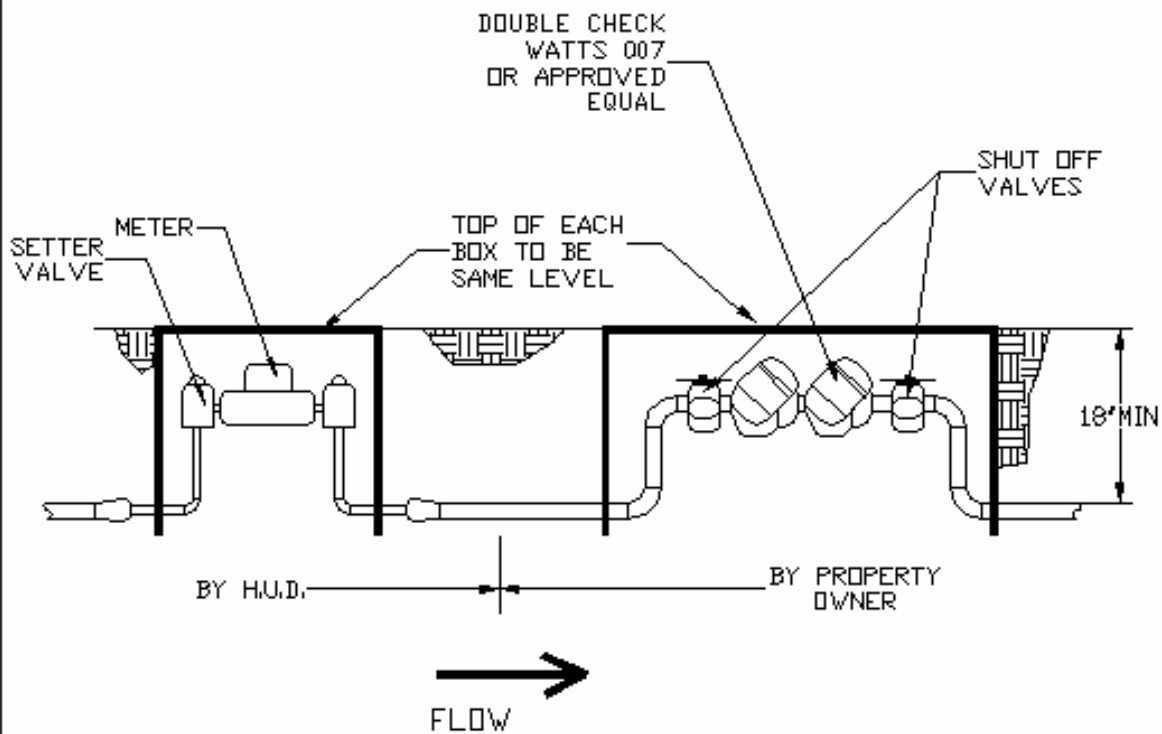

HIXSON UTILITY DISTRICT	BACKFLOW PREVENTER FOR LAWN SPRINKLER SYSTEMS	REVISED MAR 2008	DRAWING NO.
			FS 3

CARRIER SIZE	SPIRAL WELDED STEEL	
	CASING SIZE	WALL THICKNESS OF CASING PIPE
2'	4'	1/4"
4'	8'	1/4"
6'	12'	1/4"
8'	16'	1/4"

NOTE: T.D.O.T. OR RAILROAD  
MAY REQUIRE ADDITIONAL  
SPECIFICATIONS

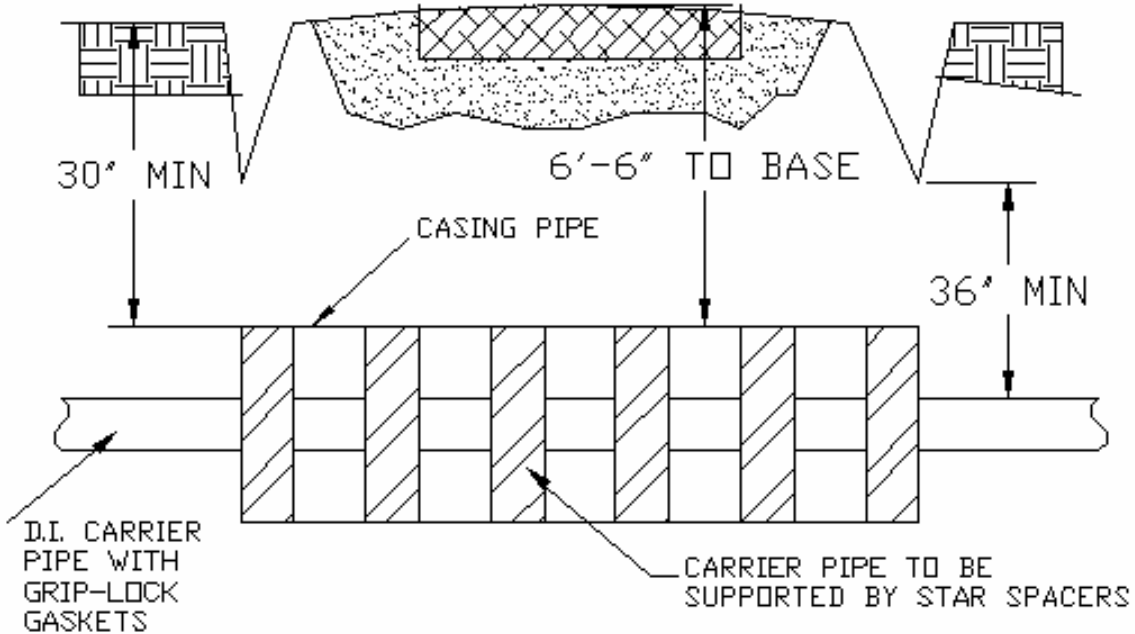

HIXSON UTILITY DISTRICT	HIGHWAY CROSSING DETAIL	DWG # HC-1
-------------------------------	----------------------------	---------------

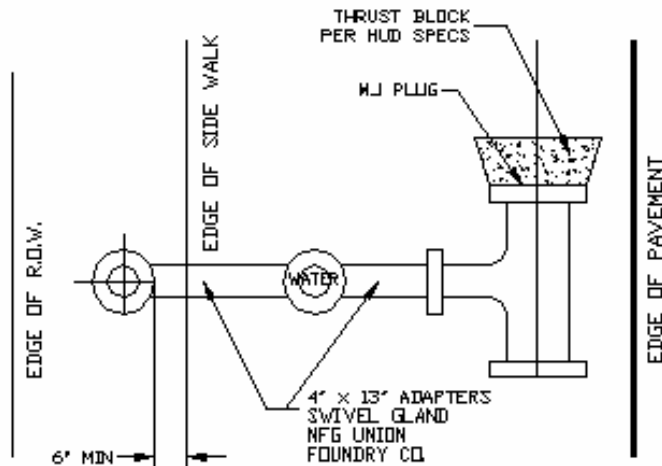

TOP VIEW

- NOTES:
1. HYDRANT IS TO BE IN GRASS.
  2. VALVE MAYBE IN SIDEWALK
  3. HYDRANT NOZZLE TO FACE STREET

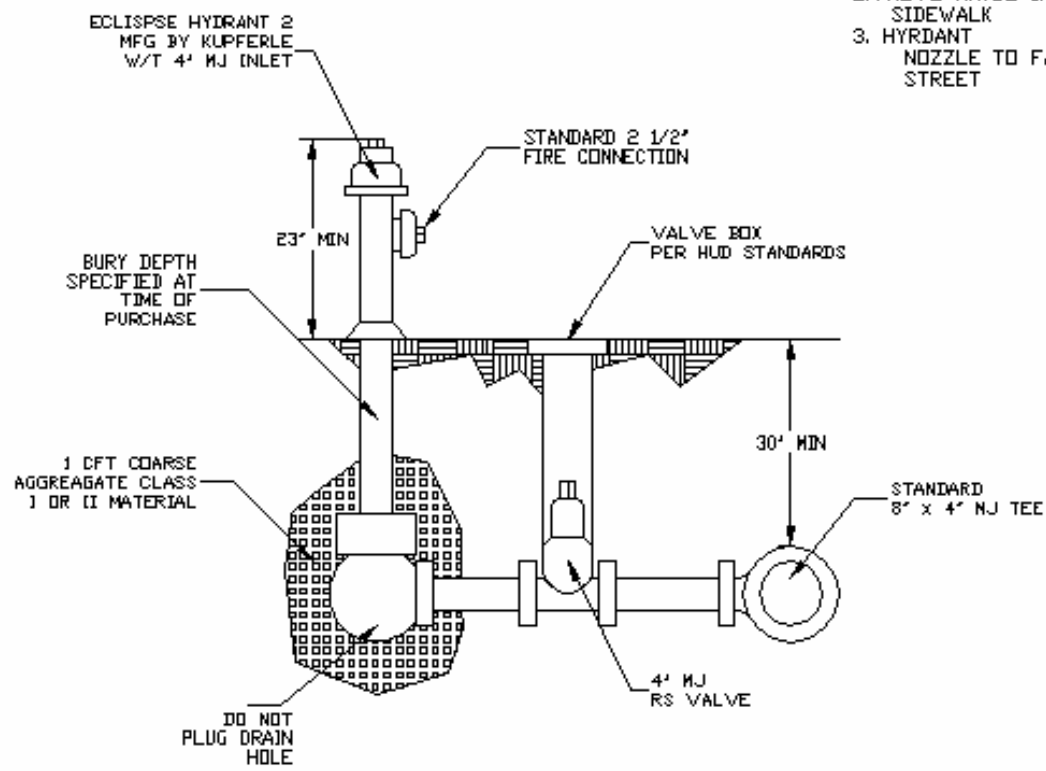

SIDE VIEW

HIXSON UTILITY DISTRICT	THRUST BLOCKING DETAILS FOR TEES AND BENDS	REVISED JAN 08	DRAWING NO. BVA-1
-------------------------	--	-------------------	----------------------

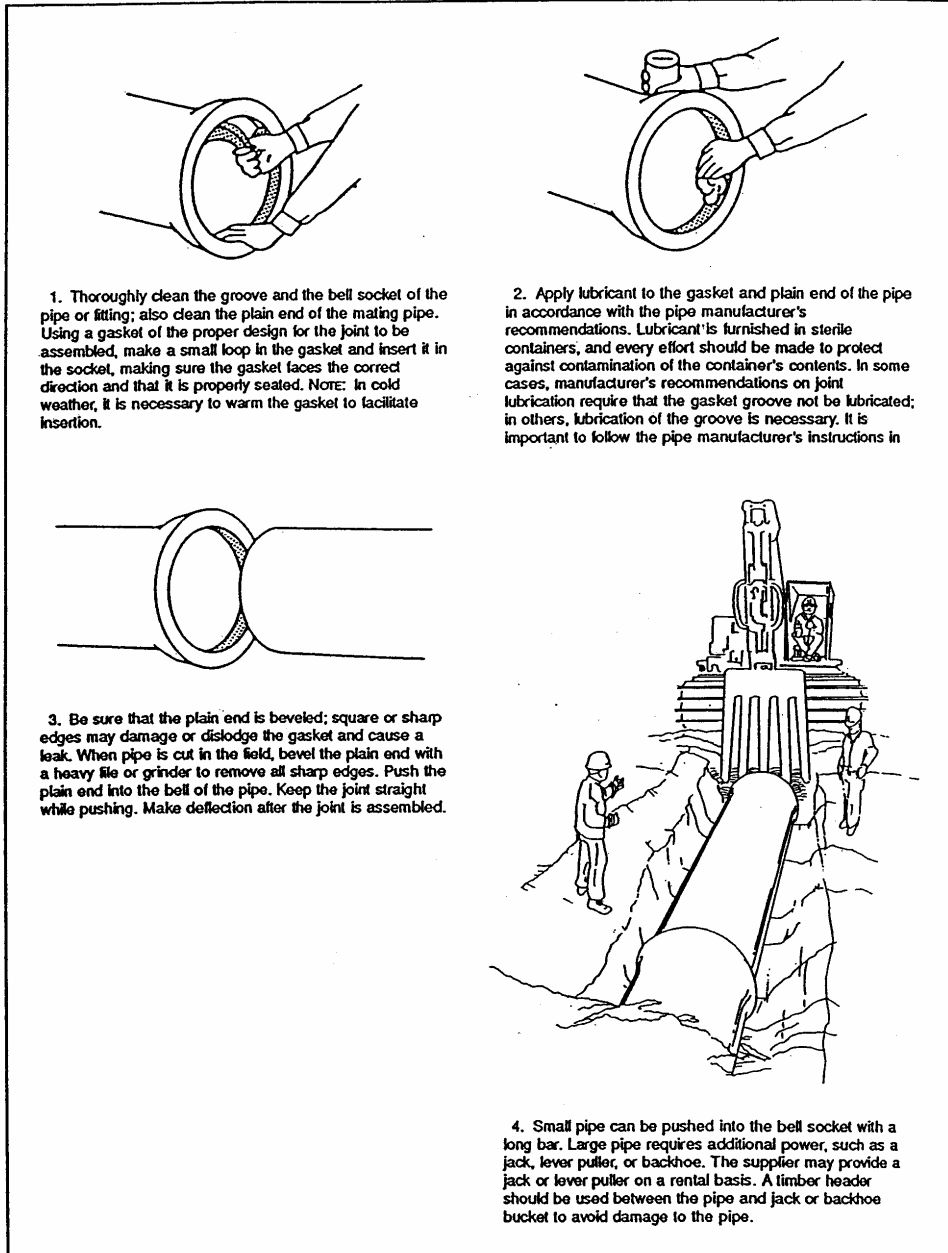

Figure 2 Push-on-joint assembly

DWG - PJA-1

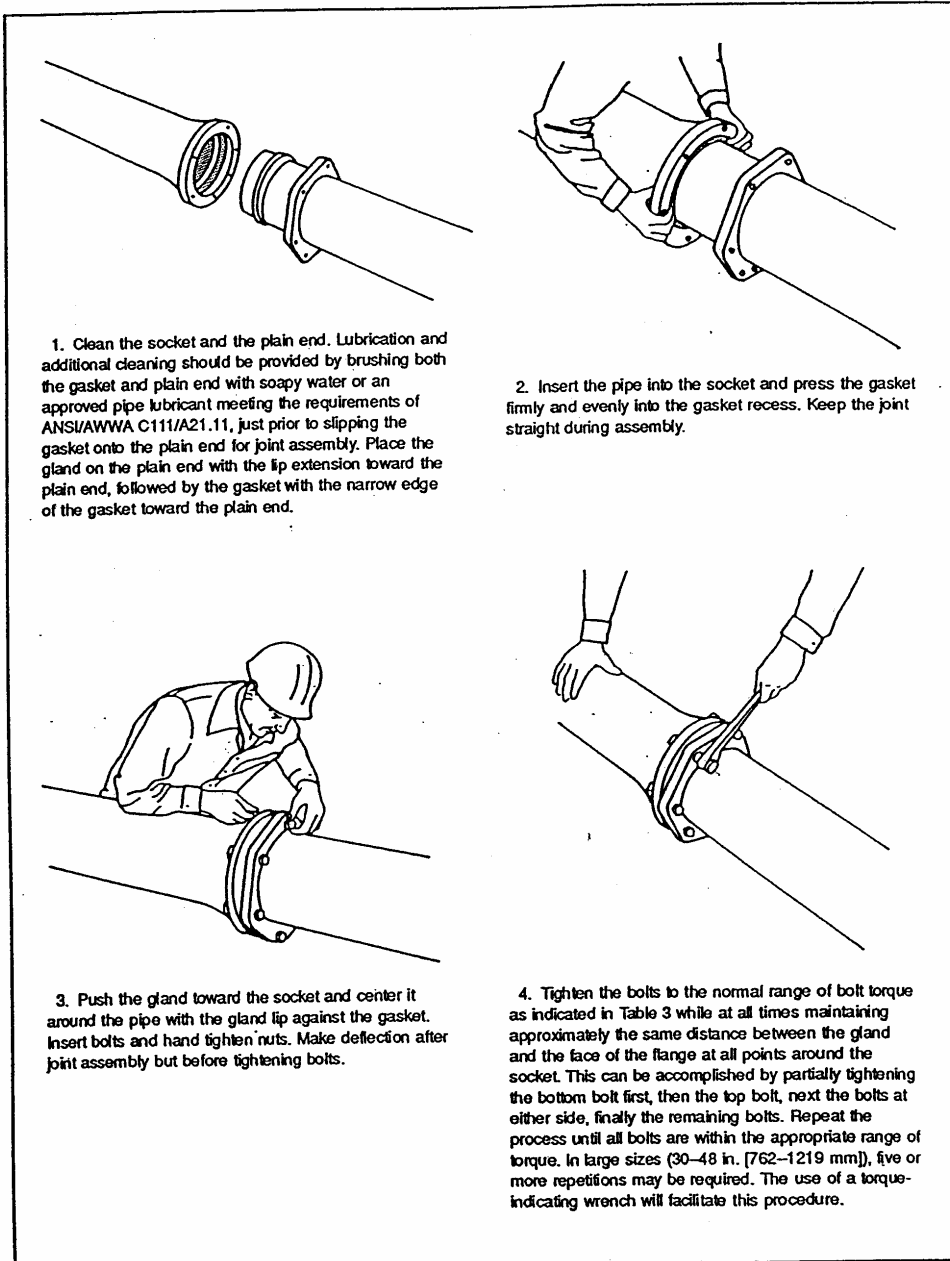

Figure 3 Mechanical-joint assembly

DWG-PJA-2

Table 5 Maximum joint deflection full-length pipe—mechanical-joint pipe

Nominal Pipe Size in. (mm)	Deflection Angle— $\theta$ deg. and min	Maximum Offset— $S^*$ in. (m)		Approx. Radius of Curve— $R^*$ Produced by Succession of Joints ft (m)	
		$L^* = 18$ ft (5.5 m)	$L^* = 20$ ft (6 m)	$L^* = 18$ ft (5.5 m)	$L^* = 20$ ft (6 m)
3 (76)	8-18	31 (0.79)	35 (0.89)	125 (38)	140 (43)
4 (102)	8-18	31 (0.79)	35 (0.89)	125 (38)	140 (43)
6 (152)	7-07	27 (0.69)	30 (0.76)	145 (44)	160 (49)
8 (203)	5-21	20 (0.51)	22 (0.56)	195 (59)	220 (67)
10 (254)	5-21	20 (0.51)	22 (0.56)	195 (59)	220 (67)
12 (305)	5-21	20 (0.51)	22 (0.56)	195 (59)	220 (67)
14 (356)	3-35	13.5 (0.34)	15 (0.38)	285 (87)	320 (98)
16 (406)	3-35	13.5 (0.34)	15 (0.38)	285 (87)	320 (98)
18 (457)	3-00	11 (0.28)	12 (0.30)	340 (104)	380 (116)
20 (508)	3-00	11 (0.28)	12 (0.30)	340 (104)	380 (116)
24 (610)	2-23	9 (0.23)	10 (0.25)	450 (137)	500 (152)

\*See Figure 4.

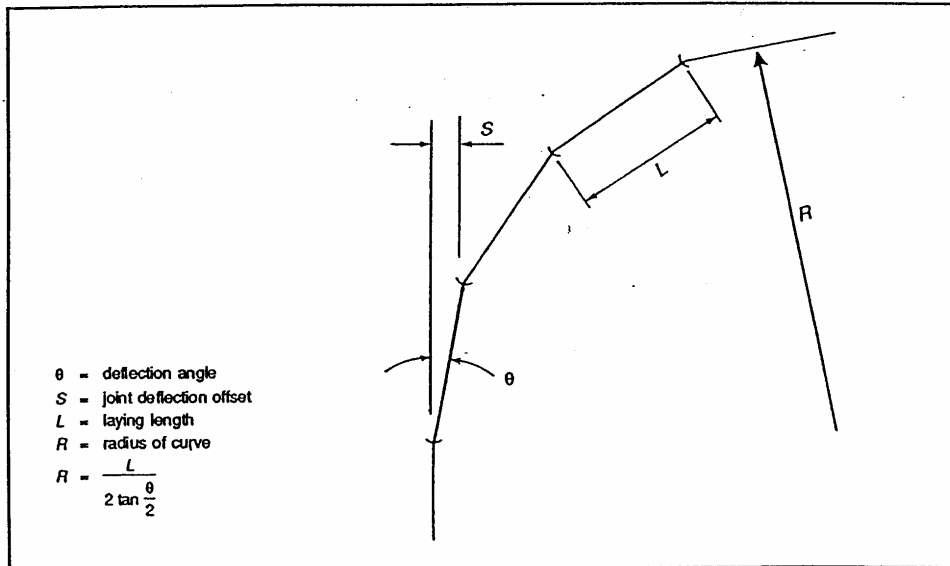

Figure 4 Pipeline curve geometry

DWG JD-1

## SECTION 02221

### TRENCHING, BACKFILLING, AND COMPACTION .

#### PART 1 GENERAL

##### 1.01 WORK INCLUDED

- A. Excavation for piped utility material.
- B. Provide necessary sheeting, shoring and bracing.
- C. Prepare trench bottom with appropriate materials,
- D. Dewater excavation as required.
- E. Place and compact granular beds, as required, and backfill.

##### 1.02 BELATED WORK

- A. Section 02110: Clearing and Grubbing
- B. Section 02210: Grading and Excavation
- C. Section 02513: Asphaltic Concrete Paving
- D. Section 03001: Concrete Work

##### 1.03 PRECAUTIONS

- A. Notify utility companies when necessary to disturb existing facilities and abide by their requirements for repairing and replacing.
- B. Protect all vegetation and other features to remain.
- C. Protect all benchmarks and survey points.

#### PART 2 PRODUCTS

##### 2.01 BEDDING AND BACKFILL MATERIALS

- A. Class I Material: Angular, 1/4 to 1 inch graded stone Including a number of fill materials that have regional

significance such as crushed stone, cinders, slag, and crushed shells.

- B. Class II Material: Coarse sands and gravels with a maximum particle dimension of 1-1/2 inch including variously graded sands and gravels containing small percentages of fines, generally granular and non-cohesive, either wet or dry.
- C. Class III Material: Fine sand and clayey gravels, including fine sands, sand-clay mixtures, and gravel-clay mixtures.
- D. Class IV Material: Silt, silty clays, and clays, including inorganic clays and silts of medium to high plasticity and liquid limits.
- E. Class V Material: Organic soils, as well as, soil containing frozen earth, debris, rocks larger than 1-1/2 inches and other foreign material.

## 2.02 BEDDING AND BACKFILL MATERIALS - STORM SEWERS

NOT APPLICABLE

## PART 3 EXECUTION

### 3.01 PREPARATION

- A. Install barriers and other devices to protect areas adjacent to construction.
- B. Protect and maintain all benchmark and other survey points.
- C. Follow state, county and city requirements for site run off controls. File all applicable state, county and city permits as required.

### 3.02 EXCAVATION TRENCHES

- A. Perform in such a manner as to form a suitable trench in which to place the pipe and so as to cause the least inconvenience to the public. Minimum trench width shall be 1 foot plus the normal diameter of the pipe.
- B. Maximum width at the crown of the pipe - 2 feet plus the nominal diameter of the pipe.
- C. Cut pavement along neat, straight lines with either a pavement breaker or pavement saw.
- D. Trench depth: for water lines - sufficient to provide minimum cover of 30 Inches over the top of the pipe; maximum depth will not exceed 42" over top of pips unless there is prior approval from District.
- E. Align trench as shown on the Plans unless a change is necessary to miss an unforeseen obstruction.
- F. For water pipe, shape the bottom of the trench to provide uniform bearing of the pipe on undisturbed earth throughout its entire length. Dig bell holes to aid in securing uniform

support of the pipe.

G. Waterline location will be 21 feet from the center line of the street or 4 feet in back of curb for multi-lane roadways. Waterlines will be located on the South and West sides of the streets.

H. When unstable soil is encountered at the trench bottom, remove it to a depth required to assure support of the pipeline and backfill to the proper grade with coarse aggregate AASHTO M-43, Size No. 2 or 3.

I. Remove rock encountered in trench excavation to a depth of 6 inches below the bottom of the pipe barrel, backfill with an approved material, and compact to uniformly support the pipe. In no case shall solid rock exist within six (6) inches of the finished pipeline.

J. When rock borings or soundings are provided, they are for information only and do not guarantee existing conditions. Make such investigations as deemed necessary to determine existing conditions.

### 3.03 SHEETING, SHORING, AND BRACING

A. When necessary or when directed by the Engineer, furnish, put in place, and maintain such sheeting, bracing, etc., as may be required to support the sides of the excavation and to prevent movement.

B. Take care to prevent voids outside the sheeting.

C. If voids are formed, immediately fill and ram to the satisfaction of the Engineer.

D. Devise plans for performing this work subject to the approval of the Engineer.

E. Unless adjacent facilities will be injured, remove all sheeting shoring, and bracing after backfill has been placed to a depth of 18 inches over the pipeline.

F. Cut shoring off at the top of the pipe and leave the lower section in the trench.

### 3.04 USE OF EXPLOSIVES

A. Conduct all blasting operations in accordance with prevailing municipal, state or other agency regulations, codes, ordinances or laws.

B. Exercise due caution when blasting adjacent to existing structures and pipelines.

C. If structures or pipelines are damaged, promptly replace or repair them at no expense to Owner.

D. Do not conduct blasting operations within 25 feet of water, sewer, gas or other utility lines, unless otherwise directed by the Engineer.

E. Cover all shots with blasting mats to prevent flying material.

### 3.05 DISPOSAL OF EXCAVATED MATERIAL

- A. Satisfactorily dispose of all excess excavated material that cannot be used for or is not suitable for embankments

### 3.06 UNAUTHORIZED EXCAVATION

- A. All excavation outside or below the proposed lines and grades shown on the Plans or directed by the Engineer.
- B. Backfill areas of unauthorized excavation with the type material necessary (earth, rock or concrete) .to insure the stability of the structure of construction involved.
- C. NOT APPLICABLE

### 3.07 REMOVAL OF WATER

- A. Keep excavated areas free of water while work is in progress.
- B. Well-pointing shall be performed if required.
- C. Take particular precautions to prevent the displacement of structures or pipelines as a result of accumulated water.

### 3.08 OBSTRUCTIONS

- A. Obstructions shown on the Plans are for information only and do not neither guarantees their exact locations nor that of other obstructions are not present.
- B. When utilities or obstructions are not shown on the plans but are present off the roadway at the location of the proposed pipeline route, the Contractor may request to relocate the pipeline in the roadway if necessary to avoid disturbing the utility or obstructions.
- C. NOT APPLICABLE
- D. Exercise due care in excavating adjacent to existing obstructions and do not disturb same unless absolutely necessary.
- E. In the event obstructions are disturbed, repair or replace as quickly as possible to the condition existing prior to their disturbance.
- F. If desired by the utility company, pay for the repair or replacement work performed by the forces of the utility company or other appropriate party.
- G. If replacement or repair of disturbed obstructions is not performed after a reasonable period of time the Owner may have the necessary work done and deduct the cost of same from payments to the Contractor.

### 3.09 STORM SEWER BEDDING

NOT APPLICABLE

### 3.10 GRAVITY SANITARY SEWER BEDDING

NOT APPLICABLE

### 3.11 BEDDING FOR WATERLINES

- A. Bed in a trench cut in natural ground.
- B. Dig bell holes to assure uniform support throughout the entire length of pipe.
- C. Excavate the trench in such a manner as to form a suitable bed on which to place the pipe. .

### 3.12 INITIAL BACKFILLING

- A. Do not begin backfilling before the Engineer has inspected the grade and alignment of the pipe, the bedding of the pipe, and the joints between the pipes. If backfill material is placed over the pipe before an inspection is made, reopen the trench in order for an inspection to be made.
- B. Perform backfilling by hand, together with tamping, until fill has progressed to 18" above the top of the pipe.
  - 1) Deposit Class I granular material (where required) or loose soil free from lumps, clods, frozen material or stones in layers approximately 6" thick.
  - 2) Compact by hand, or with manually operated machine tampers actuated by compressed air or other suitable means.
  - 3) Use tamps and machines of a suitable type which do not crush or otherwise damage the pipe.

### 3.13 FINAL BACKFILLING

- A. After the backfill has reached a point 18" or more above the top of the pipe, perform final backfilling depending upon the location of the work and danger from subsequent settlement.
- B. Backfilling in Unimproved Areas:
  - 1) Dispose of and replace all soft or yielding material which is unsuitable for trench backfill with suitable material.
  - 2) Deposit backfill to the surface of the ground by dragline bulldozer, or other suitable equipment in such a manner so as not to disturb the pipe.
  - 3) Neatly round sufficient surplus excavated material over the trench to compensate for after settlement.
  - 4) Dispose of all surplus excavated material.
  - 5) Prior to final acceptance, remove all mounds to the elevation of the surrounding terrain.
- C. Backfilling Beneath Driveways and Streets where Non-Rigid and Rigid Type Surfacing is to be replaced:
  - 1) Use Class I granular material of either crushed limestone or crushed gravel of high weight and

density.

- 2) Carefully deposit in uniform layers, not to exceed 6" thick.
- 3) Compact each layer thoroughly by rolling, ramming and tamping with tools suitable for that purpose in such a manner so as to not disturb the pipe.

D. Backfilling of Shoulders Along Streets and Highways:

- 1) Backfilling methods and materials for shoulders along streets and highways shall be in accordance with the requirements of governing local, county, or state departments maintaining the particular roadway or highway.
- 2) Replace with similar materials, all shoulders which may be damaged or destroyed as a result of pipe trenching.
- 3) NOT APPLICABLE
  
- 4) Where shoulders along state highways have sealed coat surfaces, replace with double bituminous seal in accordance with Section 02550.
- 5) NOT APPLICABLE

E. Crushed Stone for Pavement Maintenance and Shoulder Replacement:

- 1) Where possible, salvage and reuse all base material that is removed during construction.
- 2) Wet and thoroughly compact crushed stone and blade to tie into the existing surface prior to final acceptance.
- 3) NOT APPLICABLE

3.14 MEASUREMENT AND PAYMENT - TRENCHING, BEDDING AND BACKFILLING

TO BE DETERMINED BY DEVELOPER

3.15 MEASUREMENT AND PAYMENT - UNDERCUT BEDDING

TO BE DETERMINED BY DEVELOPER

3.16 MEASUREMENT AND PAYMENT - CRUSHED STONE FOR PAVEMENT MAINTENANCE AND SHOULDER REPLACEMENT

TO BE DETERMINED BY DEVELOPER

END OF SECTION

SECTION 02223  
SEPERATION OF WATER MAINS AND SEWERS

3.21 General - The following factors should be considered in providing adequate separation:

- a. materials and type of joints for water and sewer pipes;
- b. soil conditions;
- c. service and branch connections into the water main and sewer line;
- d. compensating variations in the horizontal and vertical separations;
- e. space for repair and alterations of water and sewer pipes;
- f. off-setting of pipes around manholes;
- g. water mains and sanitary or storm sewers shall not be laid in the same trench.

3.22 Parallel Installation

- a. Normal conditions - Water mains shall be laid at least 10 feet horizontally from any sanitary sewer, storm sewer or sewer manhole, whenever possible; the distance shall be measured edge-to-edge.
- b. Unusual conditions - When local conditions prevent a horizontal separation of 10 feet, a water main may be laid closer to a storm or sanitary sewer provided that:
  1. the bottom of the water main is at least 18 inches above the top of the sewer,
  2. where this vertical separation cannot be obtained, the sewer shall be constructed of materials and with joints that are equivalent to water main standards of construction and shall be pressure tested to assure water-tightness prior to backfilling.

3.23 Crossings

- a. Normal conditions - Water mains crossing house sewers, storm sewers or sanitary sewers shall be laid to provide a separation of at least 18 inches between the bottom of the water main and the top of the sewer, whenever possible.
- b. Unusual conditions - when local conditions prevent a vertical separation as described in Section 3.22a, the following construction shall be used:
  1. Sewers passing over or under water mains should be constructed of the materials described in Section 3.22b2.
  2. Water mains passing under sewers shall, in addition, be protected by providing:
    - i. a vertical separation of at least 18 inches between the bottom

of the sewer and the top of the water main;

- ii. adequate structural support for the sewers to prevent excessive deflection of joints and settling on and breaking the water mains;
- iii. that the length of water pipe be centered at the point of crossing so that the joints will be equidistant and as far as possible from the sewer.
- iv. both the sewer and the water main shall be constructed of water pipe and tested in accordance with Section 9.1.5.

3.24 Sewer manholes - No water pipe shall pass through or come into contact with any pan of a sewer or sewer manhole.

3.3 SURFACE WATER CROSSINGS - Surface water crossings, both over and under water, present special problems which should be discussed with the Department before final plans are prepared.

3.31 Above-water crossings - The pipe shall be:

- a. adequately supported;
- b. protected from damage and freezing;
- c. accessible for repair or replacement.

3.32 When crossing water courses which are greater than 15 feet in width:

- a. The pipe shall be of special construction, having flexible, watertight joints;
- b. Valves shall be provided at both ends of water crossing so that the section can be isolated for test or repair; the valves shall be easily accessible and not subject to flooding;
- c. Sampling taps should be available at each end of the crossing;
- d. Permanent taps should be made for testing and locating leaks.

3.4 CROSS CONNECTIONS

- a. There shall be no physical connection between the distribution system and any pipes, pumps, hydrants, or tanks whereby unsafe water and other contaminating materials may be discharged or drawn into the system.
- b. The approval of the Department shall be obtained for interconnections between potable water supplies.
- c. Neither steam condensate nor cooling water from engine jackets or other heat exchange devices shall be returned to the potable water supply.

3.5 WATER SERVICES AND PLUMBING - Water services and plumbing shall conform to relevant local and/or state plumbing codes, or to the Standard Plumbing Code.

### 3.6 MATERIALS - GENERAL

- a. Pipe selected shall have been manufactured in conformity with the latest standards issued by the American Water Works Association, if such standards exist, and be acceptable to the Department.
- b. in the absence of such standards, pipe meeting applicable ASTM and ANSI criteria and acceptable to the Department may be selected.
- c. Used water mains that meet these standards may be used again, after the pipe has been thoroughly cleaned and restored practically to its original condition.
- d. Packing and jointing materials used in the joints of pipe shall meet the standards of the American Water Works Association or the Department.
- e. Mechanical joints or slip-on joints with rubber gaskets are preferred.

## SECTION 02305

### BORING AND JACKING

#### PART 1 GENERAL

##### 1.01 WORK INCLUDED

- A. Placing casing and carrier pipe by boring and jacking under highways and railroads.

##### 1.02 RELATED WORK

- A. Appropriate Piped Utility Sections (2700 Numbers)

##### 1.03 REGULATIONS AND PERMITS

- A. Permits for crossing highways or railroads will be obtained by the Developer.
- B. For highway crossings, satisfy the Highway Department to the extent of the Developer's-posted surety bonds.
- C. For railroad crossings, furnish certificates of insurance in amounts established by the railroad company, naming the railroad as the insured.

#### PART 2 PRODUCTS 2.01

STEEL CASING PIPE

A. Minimum yield strength of 35,000 psi.

B. Minimum thickness:

Nominal Diameter (Inches)	Minimum Thickness (Inches)
Under 14	0.188
14-16	0.219
18	0.250
20	0.281
22	0.312
24	0.344
26	0.375
28-30	0.406
32	0.438
34-36	0.469
38-42	0.500

C. Where casing pipes are to be installed under railroads, provide with a protective bituminous coating, cathodic protection; or an increased wall thickness one standard size greater than that shown above.

Increase a minimum of 0.063” except for diameters under 12-3/4”.

D. Steel casing pipe shall be of continuous weld construction and installed with welded joints.

2.02 CARRIER PIPE

A. Carrier pipe installed in the casing pipe shall be as specified under the appropriate Piped Utility Section (section 2713) and as shown the drawings.

PART 3 EXECUTION

3.01 GENERAL REQUIREMENTS

A. Perform all crossings according to the requirements of the governing highway department or Railroad Company.

B. Notify the appropriate authorities involved and request their supervisory services during construction.

C. Provide necessary safeguards to protect the crossing.

D. Not Applicable

3.02 INSTALLATION

A. Perform all crossings in the manner directed by the highway department or railroad company.

- B. Dry bore an opening under the crossing.
- C. Jack the casing pipe, of the type and size specified, into the bored opening.
- D. Install the appropriate carrier pipe into the casing pipe. The pipe is to be connected with grip-lock gaskets and surrounded by metal spacers. Star Type Design
- E. Test the carrier pipe according to the appropriate Piped Utility Sections (2700 number).

3.03 MEASUREMENT AND PAYMENT

TO BE DETERMINED BY DEVELOPER

END OF SECTION

SECTION 02713

WATER DISTRIBUTION SYSTEMS

PART 1 GENERAL

1.01 WORK INCLUDED

- A. Installation, testing and disinfections of water lines and appurtenances.

1.02 RELATED WORK

- A. Section 02221: Trenching, Backfilling and Compaction
- B. Section 02223 Separation of Water Mains and Sewers
- C. Section 02305: Boring and Jacking

PART 2 PRODUCTS

2.01 POLYVINYL CHLORIDE PIPE (PVC) AND FITTING

NOT ACCEPTED

2.02 DUCTILE IRON PIPE AND FITTINGS

A. Pipe

- 1) Manufactured in accordance with AWWA C-151 (ANSI A21.51) and

AWWA C-111 (ANSI A21.11).

- 2) A cement lining meeting the requirements of AWWA C-104 (ANSI 21.4).
- 3) A minimum of 1 mil thick bituminous coating on the outside surface.
- 4) Clearly marked with manufacturer's name, D.I. or Ductile, weight, class or nominal thickness and casting period.
- 5) Unless otherwise specified or shown on the plans, ductile iron pipe shall be pressure class 350 for 12" diameter pipe and less and pressure class 250 for 14" diameter pipe and larger.

#### B. Fittings

- 1) Tapping sleeves M.J. Mueller H-615 or U.S. Pipe T-9 200 psi working pressure.
- 2) Fitting M.J. size 4" through 24" 350 psi.
  - a) Manufactured in accordance with AWWA C-153 (ANSI A-21.53).
  - b) All valves shall be fusion bonded epoxy coating meeting AWWA C-116 (ANSI A-21.16) applied to the interior and exterior of valves.
  - c) All other fitting shall have either a fusion bonded epoxy coating inside and out in accordance with AWWA C-116 (ANSI A21.16) or an inside cement lining seal coated with an asphaltic material meeting the requirements of AWWA C-104 (ANSI A-21.4) and an asphaltic outside coating in accordance with AWWA C-153 (ANSI A-21.53).
- 3) Fitting M.J. larger than 24" 250 psi.
  - a) Manufactured in accordance with AWWA C-153 (ANSI A-21.10).
  - b) All valves shall be fusion bonded epoxy coating meeting AWWA C-116 (ANSI A-21.16) applied to the interior and exterior of valves.
  - c) All other fitting shall have either a fusion bonded epoxy coating inside and out in accordance with AWWA C-116 (ANSI A-21.16) or an inside cement lining seal coated with an asphaltic material meeting the requirements of AWWA C-104 (ANSI A-21.4) and an asphaltic outside coating in accordance with AWWA C-153 (ANSI A-21.53).

### 2.03 SERVICE PIPE

- A. To be furnished and installed by DEVELOPER.
- B. To be installed at property corners only.
- C. One continuous piece of K type copper, no couplings.

### 2.04 WATER SERVICE ASSEMBLIES

A. Water Meters

TO BE INSTALLED BY District (Meter Installation Fee by Developer or Owner)

B. Water Main Connections (see drawing WSA-1)

- 1) Direct tap water main for 1" corporation stop in the upper half of the pipe at a 45-degree angle toward the property.
- 2) Do not exceed the pipe manufacturers recommended maximum tap size.

C. Corporation stop to be 1" brass compression manufactured by one of the following:

- 1). Ford
- 2). Muller
- 3). A. Y. McDonald

D. Connecting piping is to be 1" K type copper tubing.

E. Curb Stop to be 1" brass compression manufactured by one of the following

- 1). Ford
- 2). Muller
- 3). A. Y. McDonald.

F. Meter Yokes

TO BE INSTALLED BY District

G. Meter Boxes

TO BE INSTALLED BY District

H. Pressure Reducing Valves for Service Assemblies

- 1). To be furnished and installed by home owner or builder
- 2). To be used on all services.
- 3). To be located where recommended by District and manufacturer.

## 2.05 VALVES AND VALVE BOXES

A. Gate Valves

- 1). AWWA C-509 Resilient Seal Gate Valves
  - a). Mueller Series A-2370-20
  - b). U.S. Pipe Metroseal 250 Gate Valves
- 2). Iron body, bronze mounted, resilient wedge gate, parallel seat, non-rising stem type.
- 3). Stuffing boxes: O-ring seal type with two (2) rings in stem located above the thrust collar.

- 4). 2" square wrench nut for operation of the valve.
- 5). Minimum design working water pressure of 200 psi test pressure of 400 psi for valves with diameter 2" to 12" and 150 psi with test otherwise specified or shown on plans.
- 6). Joints; Mechanical Joint, both ends in accordance with AWWA C-111 (ANSI A-21.11) with bolts, glands and rubber gaskets.
- 7). Bonnet of body markings: Manufacturers name, year or casting, size, pressure rating, and OPEN direction.
- 8). Open by counter-clockwise operation.

Butterfly Valves

NOT ACCEPTED

B. Water Main Connections:

- 1) Tap water mains in the upper half of the pipe at a 45 degree angle or provide brass tapped couplings with AWWA threads.
- 2) Do not exceed the pipe manufacturer's recommended maximum tap size.
- 3) NOT APPLICABLE

C. Corporation and Curb Stops;

TO BE FURNISHED AND INSTALLED BY DEVELOPER  
(corporation & curb stops shall be as manufactured by Ford, Mueller, or A.Y. McDonald)

D. Meter Yokes:

TO BE INSTALLED BY DISTRICT

E. Meter Boxes:

TO BE INSTALLED BY DISTRICT

F. Pressure Reducing Valves for Service Assemblies:

To Be Furnished And Installed By Home Owner Or Customer Where The Static Pressure Is Greater Than 80 psi. Located Where Recommended By District.

2.05 VALVES AND VALVE BOXES

A. Gate Valves:

- 1) AWA C-509. Mueller Series A-2370-20, U. S. Pipe Metroseal 250 Gate Valves or

approved equal.

- 2) Of iron body, bronze mounted, resilient wedge gate, parallel seat, non-rising stem type.
- 3) Stuffing boxes: 0-ring seal type with two (2) rings in the stem located above the thrust collar.
- 4) 2" square wrench nut for operation of the valve.
- 5) Minimum design working water pressure of 200 psi test pressure of 400 psi for valves with diameters 2"-12" and 150 psi with test otherwise specified or shown on the Plans.
- 6) Joints: Mechanical Joint, both end. ANSI A-21.11 (AWWA C-III). With bolts, glands and rubber gaskets.
- 7) Bonnet of body markings: Manufacturer's name, year or casting, size, pressure rating, and OPEN with direction.
- 8) Open by counter-clockwise operation.

B. Butterfly Valve:

NOT ACCEPTED

C. Main Line Pressure Reducing Valves:

NOT APPLICABLE

D. Valve Boxes:

1. Cast iron, 2 or 3 piece, slip type when located in paved area or roadway, screw type other locations with shaft diameter of not less than 5". As manufactured by Acheson Foundry or equal.
2. Heavy roadway type equipped with a cover containing the word "Water" in raised letters on the top.
3. Base of such size as to permit its installation without allowing it to come in contact with either the valve or the pipe.

2.06 AIR RELEASE ASSEMBLIES

If Required Submit Detail To District For Approval

2.07 FIRE HYDRANTS AND BLOW-OFF HYDRANTS

A. Fire Hydrants;

- 1) AWWA C-502. City of Chattanooga standard as manufactured by Mueller A-421 Centurion or U. S. Pipe Metropolitan "G" series.
- 2} Cast Iron bodies, fully bronze mounted, designed for operation at a working water pressure of 150 psi.

- 3) Furnish with two 2 1/2" threaded brass hose nozzles and one threaded brass pumper nozzle 4" diameter.
- 4) Compression type main valve 4 1/2" In diameter faced with a suitable yielding material such as rubber, leather, or balata.
- 5) So designed that, when it is installed, no excavation is required to remove the main valve or the movable parts of the drain valve.
- 6) Inside diameter of barrel: at least 120 percent of the hydrant valve size.
- 7) Inlet connection: minimum of 6" mechanical joint. on all lines, unless otherwise specified or shown on the plans.
- 8) Equipped with safety flange located not more than 2" above ground and a two piece shaft break-away assembly.
- 9) Open on counter-clockwise operation.
- 10) Shop paint and mark in accordance with AWWA C-502. Color yellow.
- 11) Cast markings: manufacturer's name, size of the main valve, year of manufacture, and direction of opening.
- 12) Field touch-up, if the surface has been marred, with paint supplied by the manufacturer of the same color and type as that used during shop painting.
- 13) Examination of material; prior to installation, all hydrants shall be inspected for direction of opening, nozzle threading, operating-nut and cap-nut dimensions, tightness of pressure-containing bolting, cleanliness of inlet elbow, handling damage, and cracks. Defective hydrants shall be marked and held for final disposition as coaled for by the specifications.
- 14) All fire hydrants shall have a 6" rubber flapper check valve between the valve and the hydrant. The check valve shall have a ductile iron body and cover, stainless steel bolts, and ductile iron disk fully encapsulated in EPDM with nylon reinforced flex area. Valve shall be as manufactured by Milliken Valve Company or shall be Mueller Super Centurion 250 High Security hydrants.
- 15) Placement: All fire hydrants shall stand plumb and shall have their nozzles parallel with and or at right angles to the curb, blow-off hydrants will have the nozzle facing the street, with pumper nozzle facing the curb.
- 16) Hydrants shall be set to the established grade, with the lowest nozzle at least 12 inches (308 mm) above the ground or as required by the specifications. The lowest nozzle shall be installed away from the curb line at a sufficient distance to avoid damage from or to vehicles. Traffic-model hydrants shall be installed so that the breakaway flange is not less than 2 inches (50 mm) or more than 6 inches (152 mm) above established grade.
- 17) Each hydrant shall be connected to the main with a 6-inch (152) or larger diameter branch

controlled by an independent valve, unless otherwise specified. The valve shall be restrained to allow shut off when the hydrant is to be removed.

- 18) When a dry-barrel hydrant is set in soil that is impervious, drainage shall be provided at the base of the hydrant by placing coarse gravel from the bottom of the trench to at least 6 inches (152 mm) above the drain port opening in the hydrant and to a distance of 1 foot (300 mm) around the elbow. Where groundwater rises above the drain port or when the hydrant is located within 8 feet (2.4 m) (or distance required by the applicable regulatory agency) of a sanitary sewer main, or where drainage is not permitted by the applicable regulatory agency, the drain port shall be lugged and water pumped from the hydrant when freezing may occur.
- 19) When a dry-barrel hydrant with an opening port is set in clay or other impervious soil, a drainage pit 2 feet by 2 feet by 2 feet (0.6m x 0.6m x 0.6m) shall be excavated below each hydrant. The drainage pit shall be filled with coarse gravel under and around the elbow of the hydrant and to a level of 6 inches (152 mm) above the drain port. To prevent possible contamination of the water supply, do not connect hydrant drains to a sanitary sewer or storm sewer.
- 20) Location: Hydrants shall be located as shown on the plans or as specified.
- 21) Protection: In the case of hydrants that are intended to fall at the ground-line joint on vehicle impact (traffic hydrants) specific care must be taken to provide adequate soil resistance to avoid transmitting shock moment to the lower barrel and inlet connection. In loose or poor load-bearing soil, this may be accomplished by pouring a concrete collar approximately 6 inches (152 mm) thick to a diameter of 2 feet (0.6 m) at or near the ground line around the hydrant barrel.
- 22) Additional Information: AWWA manual M17 provides information regarding installation of hydrants.

#### B. Blow-Off Hydrants

- 1) Location: Blow-Off hydrants are to be installed only where specified by local codes or plans.
- 2) Installation: Shall be in accordance with Standard Drawing BVA-1.
- 3) Manufacture: Acceptable blow-off hydrants are the Eclipse 2 manufactured by Kupferle Foundry Co. with 4" M.J. inlet and 2 1/2" outlet or the A411 Post Type Hydrant manufactured by Muller Co. with a 4" M.J. inlet and 2 1/2" outlet.
- 4) Protection: Same as standard fire hydrant.

### PART 3 EXECUTION

### 3.01 PREPARATION

- A. Prior to laying pipe, prepare suitable bedding according to Section 02221.
- B. Before placing pipe in the trench, field inspect for cracks or other defects; remove defective pipe from the construction site.
- C. Swab the interior of the pipe to remove all undesirable material.
- D. Prepare the bell and remove undesirable material from the gasket and gasket recess.

### 3.02 INSTALLING WATERLINES

- A. Lay all pipes in a straight line on a uniform grade. When alignment requires deflection greater than 5 degrees between full lengths of pipe, bends will be required. Short lengths of pipe in place of bends will not be permitted.
- B. Push-on joints. Push-on joints shall be assembled as described and illustrated in drawing PJA 1 and PJA 2
- C. Mechanical joints. Mechanical joints shall be assembled as described and illustrated in drawing PJA 1 and PJA 2.
- D. Joint deflection. When it is necessary to deflect pipe from a straight line in either the horizontal or vertical plane, the amount of joint deflection shall not exceed that shown in drawing JD1. The deflections listed are maximum deflections and should not be exceeded. For design purposes, deflection should be limited to 80 percent of the values shown. Figure 4 illustrates the maximum offset S and approximate radius curve R, which are listed in drawing JD 1.
- E. Pipe cutting. Cutting pipe for insertion of valves, fittings, or closure pieces shall be done in conformance with all safety recommendations of the manufacturer of the cutting equipment. Cutting shall be done in a safe, and proper manner without creating damage to the pipe or cement-mortar lining. Pipe shall not be cut in short lengths to avoid using bends. Bends must be used when pipe exceeds 5 degrees deflection.
- F. Existing gray-iron pipe may be cut using a hydraulic squeeze cutter, abrasive pipe saw, rotary wheel cutter, guillotine pipe saw, or milling wheel saw.
- G. Ductile-iron pipe may be cut using an abrasive pipe saw, rotary wheel cutter, guillotine pipe saw, milling wheel saw, or oxyacetylene torch if recommended by the pipe manufacturer.
- H. Cut ends and rough edges shall be ground smooth, and, for push-on joint connections, the cut end shall be beveled by methods recommended by the manufacturer.
- I. ANSI/AWWA C151/A21.51 requires factory gauging of the spigot end to ensure that the outside diameter of each spigot end falls within the tolerances stipulated in that standard. Accordingly, pipes selected for cutting should be field-gauged. A mechanical-joint (MJ) gland inserted over the barrel might serve as a convenient indicator for this purpose.

### 3.03 INSTALLING APPURTENANCES

- A. Securely plug open ends of pipe at the close of each work day and during temporary discontinuance of pipe laying.

- B. Set all valves, fittings, hydrants, and other specials in a neat workmanlike manner.
- C. Use thrust blocks, as shown on the Plans, pipe anchors, or other approved means to prevent displacement or other fittings.
- D. Erect hydrants to stand plumb with the pumper nozzle facing the road.
- E. Effect drainage of hydrants by using 6 cubic feet of gravel.
- F. After thorough flushing of all dirt and debris from pipe. Close dead ends with cast iron plugs or caps and equip with blow-off assemblies, where shown on the drawings. Temporary fittings, pipe or hoses should be installed to direct the flushing water away from the pipe end.

### 3.04 HIGHWAY AND RAILROAD CROSSINGS

- A. Perform highway crossings by the open cut method, unless otherwise shown on the drawings or required by the appropriate authorities.
- B. Boring and jacking of crossings, if necessary, will be performed in accordance with Section 02305

### 3.05 WATERLINE PRESSURE TESTS

- A. After the pipe has been laid, subject all newly laid pipe or any valved section thereof to a hydrostatic pressure of at least 1.25 times the working pressure at the point of testing with 200 psi being the minimum test pressure and 250psi being the maximum test pressure acceptable.
- B. Test pressures shall;
  - 1) Not be less than 1.25 times the working pressure at the highest point along the test section.
  - 2) Not exceed the pipe or thrust restraint design pressures.
  - 3) Be of at least 2-hour duration.
  - 4) Not vary by more than +/- 5psi.
  - 5) Not exceed twice the rated pressure of closed valves or hydrants.
- C. Pressurization:
  - 1) Slowly fill each valved section of pipe with water.
  - 2) Apply the specified test pressure, based on the elevation of the lowest point of the line or section under test and correct to the elevation of the test gauge by means of a pump connected to the pipe in a manner satisfactory to the Owner.
- D. Air Removal:
  - 1) Before applying the specified test pressure, expel air completely from the pipe, valves, and hydrants.
  - 2) If permanent air vents are not located at all high points, install corporation cocks at such points to expel air as the line is filled with water?
  - 3) After all the air has been expelled, close the corporation cocks and apply the test pressure.

- 4) At the conclusion of the pressure test, remove the corporation cocks and plug or leave in place at the discretion of the Owner.

E. Examination:

- 1) Carefully examine all exposed pipe, fittings, valves, hydrants, and joints.
- 2) Repair or replace any damaged or defective pipe, fittings, valve, or hydrants that are discovered with sound material and repeat the test until it is satisfactory to the Owner.

3.06 WATERLINE LEAKAGE TESTS

A. Concurrently conduct a leakage test with the pressure test.

B. Leakage Defined: the quantity of water that must be supplied into the newly laid pipe to maintain the specified test pressure after the air in the pipeline has been expelled and the pipe has been filled with water.

C. Allowable Leakage:

- 1) Determine allowable leakage by:

$$L = \frac{NDN\sqrt{P}}{7400}$$

Where L is the allowable leakage, in gallons per hour; N is the number of joints in the tested pipeline; D is the nominal diameter of the pipe, in inches; and P is the average test pressure during the leakage test, in psig.

- 2) Allow leakage at various pressures:

Allowable Leakage Per 1000 ft of Pipeline\*  
(GALLONS PER HOUR)  
NOMINAL PIPE DIAMETER - INCHES

Avg. Test Pressure PSI	NOMINAL PIPE DIAMETER - INCHES																
	2	3	4	6	8	10	12	14	16	18	20	24	30	36	42	49	54
450	032	048	064	095	1.27	1:59	1.91	2.23	2.55	2-87	3.18	3.82	4.78	5.73	6.69	7.64	8.60
400	030	045	060	090	1.20	1.50	1-80	2.10	2-40	2.70	3.00	3.60	4.50	5.41	6.31	7.21	8.11
350	028	042	056	084	1.12	1.40	1-69	1.97	2.25	2.53	2.81	3.37	4-21	5.06	5.90	6.74	7.58
300	026	039	052	078	1.04	1.30	1-56	1.82	2.08	2.34	2.60	3.12	3.90	4.68	5.46	6.24	7.02
275	025	037	050	075	1.00	1-24	1.49	1.74	1-99	2.24	2.49	2.99	3.73	4.41	5.23	5.98	6.72
250	024	036	047	071	0.95	1.19	1.42	1.66	1.90	2-14	2.37	2.85	3.56	4.27	4.99	5-70	6.41
225	023	034	045	068	0.90	1.13	1.35	1.58	1.80	2.03	2.25	2.70	3.38	4.05	4.73	5.41	6.03
200	021	032	043	064	0.85	1.06	1.28	1.45	1.70	1-91	2.12	2.55	3.19	3.82	4.46	5.09	5.73
175	020	030	040	059	0-80	0.99	1.19	1.39	1.59	1.79	1.98	2.38	2.98	3.58	4.17	4.77	5.36
150	019	028	037	055	0.74	0.92	1.10	1.29	1.47	1.66	1.84	2.21	2.76	3.31	3.86	4.41	4.97
125	017	025	034	050	0.67	0.84	1.01	1.18	1.34	1-51	1.68	2.01	2.52	3.02	3.53	4.03	4.53
100	015	023	030	045	0.60	0-75	0.90	1.05	1.20	1.35	1.50	1.80	2.25	2.70	3.15	3.60	4.05

•For Mechanical or push-on joint pipe with 18-ft nominal lengths. To obtain the recommended allowable leakage for pipe with 20-ft.nominal lengths multiply the leakage calculated from the above table by 0.9.

If the pipeline under test contains sections of various diameters, the allowable leakage will be the sum of the computed leakage for each size.

3) When testing against closed metal-seated valves, an additional leakage per closed valve of 0.078 gal/hr/in. of nominal valve size shall be allowed.

4) When hydrants are in the test section, test against the closed hydrant.

### 3.07 ACCEPTANCE OF INSTALLATION

A. If any test of pipe laid discloses leakage greater than that specified above, locate and repair the defective material until the leakage is within the specified allowance. ,

B. Repair all visible leaks regardless of the amount of leakage.

### 3.08 CLEANING AND DISINFECTION OF WATER LINES

A. Flush water lines clean prior to disinfections.

1) Contact District Office for complete disinfections actions

B. Thoroughly disinfect waterlines prior to placing in service.

1) Use chlorine disinfecting agent applied to produce a 50.0 ppm dosage.

2) Allow water to escape from the ends of all lines to cause dispersion of the chlorine solution into all parts of the system.

3) Operate all valves and hydrants during the time disinfection is occurring.

4) Retain the chlorine solution in the lines for a period of 24 hours.

5) At the end of the 24 hour period, the residual chlorine must be a minimum of 25 ppm. Otherwise, repeat the disinfection procedure again.

6) Upon refilling the lines, collect a sample, for bacteriological analysis. If the same is acceptable, the lines may be connected to the system. Otherwise repeat the disinfection procedure until acceptable samples are obtained.

### 3.09 MEASUREMENT AND PAYMENT - WATER PIPE

TO BE DETERMINED BY DEVELOPER

### 3.10 MEASUREMENT AND PAYMENT - VALVES, HYDRANTS & SERVICE ASSEMBLIES

TO BE DETERMINED BY DEVELOPER

3.11 MEASUREMENT AND PAYMENT - FITTINGS (SPECIALLY CALLED FOR ON BID FORM)

TO BE DETERMINED BY DEVELOPER

END OF SECTION

HIXSON UTILITY DISTRICT POLICY

For the

CONTROL OF BACKFLOW AND CROSS-CONNECTIONS

Section 1. CROSS-CONNECTION CONTROL - GENERAL POLICY

1.1 Purpose. The purpose of this Policy is:

1.1.1 To protect the public potable water supply of Hixson Utility District from the possibility of contamination or pollution by isolating within the customer's internal distribution system(s) or the consumer's private water system(s) such contaminants or pollutants which could backflow into the public water systems; and,

1.1.2 To promote the elimination or control of existing cross-connections, actual or potential, between the consumer's in-plant potable water system(s) and non-potable water system(s), plumbing fixtures and industrial piping systems; and,

1.1.3 To provide for the maintenance of a continuing Program of Cross-Connection Control which will systematically and, effectively prevent the contamination or pollution of all potable water systems by cross-connection.

1.2 AUTHORITY.

1.2.1 The Federal Safe Drinking Water Act of 1974 and Amendments thereto; and

1.2.2 The Tennessee Safe Drinking Water Act, codified at Tennessee Code Annotated, Section 68-13-701 through 68-13-719 whereby the water purveyor has the primary responsibility for preventing water from unapproved sources or any other substances from entering the public potable water system.

1.2.3 Hixson Utility District Board of Commissioners Resolution: and Cross-Connection Plan dated March 6, 1978 approved by the Tennessee Department of Health and Environment.

2.2.4 FEDERAL AUTHORITY

The Federal Safe Drinking Water Act and regulations adopted for its implementation have the same requirement as outlined above. The above mentioned state regulations merely repeat the requirements and language of the Federal Safe Drinking Water Act (and regulations) that

applies to each public water supply in the USA. Therefore, these regulations can also be cited as authority for onsite visits of the customer's water distribution lines for the purpose of safeguarding against the degradation or contamination of water through cross-connections.

### 2.2.3

There is ample authority for the water purveyor to make investigations necessary to determine if the customer's water use practices endanger the purity and safety of the water being distributed and to require appropriate corrective measures, to protect the water system against the hazards of backflow. The following outlines the authority established on the state level for such activities.

#### Tennessee Code Annotated

Section 68-13-711 of the Tennessee Code Annotated specifically prohibits certain acts which may adversely affect a public water system- One of the prohibited acts is "the installation, allowing the installation, or maintenance of any cross-connection, auxiliary intake, or bypass, unless the source and quality of water from the auxiliary supply, the method of connection, and the use and operation of such cross-connection, auxiliary intake, or bypass has been 'approved by the department." Section 68-13-703 defines a cross-connection as follows: "Cross-connection means the physical arrangement whereby a public water supply is connected, directly or indirectly, with any other water supply system, sewer, drain, conduit, pool, storage reservoir, plumbing fixture, or other device which contains or may contain, contaminated water, sewage, other waste or liquid of unknown or unsafe quality which may be capable of imparting contamination to the public water supply as a result of backflow. Bypass arrangements, jumper connections, removable sections, swivel or changeover devices through which or because of which, backflow could occur are considered to be cross-connections."

This legislation prohibits all of the various hazardous connections or conditions that may allow the backflow of unsafe substances or liquids of unknown or questionable quality into potable water supply systems. Section 68-13-702 states "Recognizing that the waters of the state are the property of the state and are held in public trust for the benefit of its citizens, it is declared that the people of the state are beneficiaries of this trust and have a right to both an adequate quantity and quality of drinking water."

The regulations for implementation of the Tennessee Safe Drinking Act of 1983 requires public water systems to demonstrate that the water they distribute meets certain health related standards of quality at the ultimate users free flowing outlet. This clearly implies that the water system has authority for on site surveys and for requiring protective measures.

### 2.2.5 AWWA POLICY STATEMENT ON CROSS-CONNECTIONS

The "American Water Works Association's Policy Statement on Cross Connections" (AWWA, 1981)

emphasizes the responsibility of the water purveyor to furnish the customer with a safe and potable water under all foreseeable circumstances. This statement points out that lack of enforcement of plumbing regulations to control hazards within the customers plumbing system does not relieve the water purveyor of the responsibility for knowing how water is used within a premises and to require positive protection on the service line where the need exists or, if necessary, to discontinue water service.

(See statement on Page V).

#### Southern Building Codes (Cont'd) Page 2

Section. 107 (Cont'd) and permitted there under, shall be guilty of a misdemeanor. Each such person shall be considered guilty of a separate offense for each and every day or portion thereof during which any violation of any of the provisions of this Code is committed or continued, and upon conviction of any such violation such person shall be punished within the limits and as provided by state laws. (Emphasis added)

#### Section 301.21 PRINCIPLE NO. 21;

Plumbing systems, including fixtures, shall be maintained in sanitary condition and proper working order.

#### Section 1203 WATER SUPPLY MANDATORY?

Every building used for human occupancy or habitation in which plumbing fixtures are installed shall be provided with an ample supply of potable water.

#### Section 1204.1 BACKFLOW

The water distribution system shall be protected against backflow. Every water outlet shall be protected from backflow, preferably by having the outlet end from which the water flows spaced a distance above the flood level rim of the receptacle into which the water flows sufficient to provide a "minimum air gap" as defined in ANSI A112.1.2. Where it is not possible to provide a minimum air gap, the water outlet shall be equipped with an accessible backflow preventer complying with 1204.2. (Emphasis added)

#### Section 1204.2 APPROVAL OF DEVICES;

Devices installed in a potable water supply for the protection against backflow shall be maintained in good working condition by the person or persons having control of such devices. The Plumbing Official may inspect such devices, and if they are found to be defective or inoperative, shall require the replacement thereof.